

Instruction for Use

021546/03/14

Ultrasonic Anemometer 2D compact

4.387x.xx.xxx

from software version V2.20

Status: 03/2014



Safety Instructions

- Before operating with or at the device/product, read through the operating instructions. This manual contains instructions which should be followed on mounting, start-up, and operation. A non-observance might cause:
 - failure of important functions
 - endangerment of persons by electrical or mechanical effect
 - damage to objects
- Mounting, electrical connection and wiring of the device/product must be carried out only by a qualified technician who is familiar with and observes the engineering regulations, provisions and standards applicable in each case.
- Repairs and maintenance may only be carried out by trained staff or **Adolf Thies GmbH & Co. KG**. Only components and spare parts supplied and/or recommended by **Adolf Thies GmbH & Co. KG** should be used for repairs.
- Electrical devices/products must be mounted and wired only in a voltage-free state.
- **Adolf Thies GmbH & Co KG** guarantees proper functioning of the device/products provided that no modifications have been made to the mechanics, electronics or software, and that the following points are observed:
- All information, warnings and instructions for use included in these operating instructions must be taken into account and observed as this is essential to ensure trouble-free operation and a safe condition of the measuring system / device / product.
- The device / product is designed for a specific application as described in these operating instructions.
- The device / product should be operated with the accessories and consumables supplied and/or recommended by **Adolf Thies GmbH & Co KG** .
- Recommendation: As it is possible that each measuring system / device / product may, under certain conditions, and in rare cases, may also output erroneous measuring values, it is recommended using redundant systems with plausibility checks for **security-relevant applications**.

Environment

- As a longstanding manufacturer of sensors Adolf Thies GmbH & Co KG is committed to the objectives of environmental protection and is therefore willing to take back all supplied products governed by the provisions of "*ElektroG*" (German Electrical and Electronic Equipment Act) and to perform environmentally compatible disposal and recycling. We are prepared to take back all Thies products concerned free of charge if returned to Thies by our customers carriage-paid.
- Make sure you retain packaging for storage or transport of products. Should packaging however no longer be required, please arrange for recycling as the packaging materials are designed to be recycled.



Documentation

- © Copyright **Adolf Thies GmbH & Co KG**, Göttingen / Germany
- Although these operating instruction has been drawn up with due care, **Adolf Thies GmbH & Co KG** can accept no liability whatsoever for any technical and typographical errors or omissions in this document that might remain.
- We can accept no liability whatsoever for any losses arising from the information contained in this document.
- Subject to modification in terms of content.
- The device / product should not be passed on without the/these operating instructions.

Explanation of Symbols

- Warning for hot surface



Patent Protection

This instrument is patent-protected
Patent No.: EP 1 448 966 B1
Patent No.: US 7,149,151 B2

Operating Instructions

These operating instructions describe all possible applications and settings of the instrument. **The *Ultrasonic Anemometer 2D compact* is factory-set.**

Identification for the factory setting derives from the order No. and the respective "Factory Setting"

**Order number and Setting
see supplementary sheet
"Factory Setting"**

With these detailed operating instructions and via the serial interface of the Ultrasonic Anemometer 2D compact it is possible for the user to adapt the factory-settings to his own requirements.

Shipment

- 1 x Ultrasonic Anemometer Compact
- 1 x Operating Instructions
- 1 x Supplementary Sheet: Factory Setting
- 1 x Factory certification

FINAL

Contents

1	Models available	6
2	Application	7
3	Mode of Operation	8
3.1	Measuring Principle: Wind velocity and direction	8
3.2	Measuring principle: Acoustic virtual temperature	9
3.3	Measuring principle: Air pressure	10
3.4	Heating.....	10
4	Preparation for operation	11
4.1	Selection of installation site	11
4.2	Installation of anemometer	11
4.3	Alignment to north	12
4.4	Electrical Installation for Ultrasonic Anemometer	12
4.4.1	Cables, Cable preparation, Connector Installation	13
4.4.2	Connector Pin Assignment (Examples of Function)	14
5	Maintenance	15
6	Calibration.....	15
7	Warranty	15
8	Functional description	16
8.1	Serial communication	16
8.1.1	Duplex mode.....	16
8.1.2	Response Delay.....	17
8.1.3	General telegram structure.....	17
8.1.4	Saving of the ULTRASONIC Parameters	18
8.1.5	Return values of ULTRASONIC	18
8.1.6	Access Mode	19
8.1.7	Baud rate	20
8.1.8	Instrument ID	20
8.1.9	Bus mode.....	21
8.2	Analogue outputs	21
8.2.1	Scaling of analogue wind velocity.....	22
8.2.2	Correction to North.....	22
8.3	Instantaneous values and output of raw measured values.....	22
8.3.1	Averaging.....	22
8.4	Serial Data Output.....	23
8.4.1	Data Query	23
8.4.2	Independent telegram output	24
8.4.3	Fixed telegram formats	24
8.4.4	Generation of check sum	25
8.4.5	Status information	25
8.5	Behaviour of Instrument under extreme Conditions of Measurement Value Acquisition....	28

8.5.1	In the event of error	29
8.5.2	Behaviour of analogue outputs	29
8.5.3	Behaviour of telegram output	29
8.6	Output of all system parameters	29
8.7	Enquiry about software version	29
8.8	Forcing a restart	29
8.9	Energy-saving mode	29
8.10	Plausibility	30
8.11	Online help	30
9	Configuration of ultrasonic anemometer by customer	31
10	List of Commands	32
11	Command and description	32
12	Appendix 1 Predefined data telegrams	47
12.1	Telegram 1 VD	47
12.2	Telegram 2 VDT	48
12.3	Telegram 3 VD2	49
12.4	Telegram 00004 NMEA	50
12.5	Telegram 7 Vx, Vy, VT	51
12.6	Telegram 8 VDM	52
12.7	Telegram 9 VDPM	53
12.8	Telegram 11 PBT	55
12.9	Telegram 12 Scientific Telegram	55
13	Technical Data	56
14	Dimension Drawing	58
15	Accessories (available as optional features)	59
16	EC-Declaration of Conformity	60

Figure

Figure 1: Connector installation	13
----------------------------------------	----

Table

Table 1: Restrictions in full and half duplex mode	17
Table 2: Access key for different command levels	19
Table 3: Config. of analogue outputs WV/RXD- and WD/RXD+ with parameters AO a. SC	21
Table 4: List of predefined data telegrams	24
Table 5: Adjustment of averaging periods with parameter AV	34
Table 6: List of baud rates with telegram BR	35
Table 7: Conversion factors between different wind velocities	41

1 Models available

Description	Article- No. *	Parameter	Output / Interface/ Equipment
US-Anemometer 2D compact	4.3875.0X.XXX	Wind velocity Wind direction Virtual temperature	- 0..20mA/0...10V (4...20mA/2...10V) - RS485/ 422 - 8 pole plug connection - heating for: base plate cover plate Sensor receiving sockets of the US-transducer US-transducer - hard-anodized housing
	4.3875.1X.XXX	Wind velocity Wind direction Virtual temperature	- w/o heating for US-transducer
	4.3875.2X.XXX	Wind velocity Wind direction Virtual temperature Barometric air pressure	- with optionally integrated Baro-transmitter
	4.3875.XX.XXX	Depending on article nol.	Configuration concerning - outputs - data telegrams - scaling - etc.

* The complete article-no. results from the arranged equipment and configuration.

FINAL

2 Application

The **Ultrasonic Anemometer 2D compact** is used to detect the horizontal components of **wind velocity** and **wind direction** in 2 dimensions in particular sturdy design. In addition, the **virtual temperature** is measured.

Optionally, the measurement of the “atmospheric air pressure (absolute)” is possible.

The instrument is especially suited for application in the fields of

- Industrial automation
- Regenerative power generation (wind power plants)
- Building automation
- Wind measuring systems for ships
- Traffic engineering/ control system

Due to the measuring principle the instrument is ideal for inertia-free measurement of gusts and peak values.

Output of the measured values can be either digital and / or analogue.

The analogue and digital interfaces operate in electrical isolation from supply and housing potential. Thus, there is no galvanic connection, which might result in a superposition of interference currents or voltages on the output signals.

Digital output: An RS485/422 is available for serial communication. It can be operated in full or half-duplex mode. For the output of measured values there are a number of pre-defined telegrams (e.g. WV, WD, WVx, WVy, NMEA etc.).

Analogue outputs: Wind velocity and direction are output either as a power or voltage signal. Individual measuring range scaling of the analogue outputs for WV and WD are selectable.

The serial or analogue output of the data is either as an instantaneous value or as a gliding mean.

The instrument is automatically heated if necessary with critical ambient temperatures. This also ensures functionality with snowfall and sleet and minimises the risk of malfunctions due to icing-up.

Thanks to the optional integrated ultrasonic converter heating the instrument is especially suited to cope with difficult icing conditions in high mountains and in other critical locations.

The instrument is equipped with a battery-buffered real-time-clock, so that the data telegrams are output with date- and time-stamp.

Thanks to its specifically hard-anodized surface, instrument **is especially suited for “maritime application”**.

3 Mode of Operation

The **Ultrasonic Anemometer 2D compact** consists of 4 ultrasonic transformers, in pairs of two facing each other at a distance of 200 mm. The two resulting measurement paths are vertical to each other. The transformers function both as acoustic transmitters and receivers.

The electronic control system is used to select the respective measurement path and its measuring direction. When a measurement starts, a sequence of 4 individual measurements is performed in all 4 directions of the measurement paths in a basis measuring cycle of one msec.

The measuring directions (sound propagation directions) rotate clockwise.

The mean values are worked out from the 4 individual measurements of the path directions and used to make further calculations.

The time required for a measuring sequence is exactly 10,0 msec (8 ms measuring sequence +2ms analysis) at the maximum measuring speed.

3.1 Measuring Principle: Wind velocity and direction

The speed of propagation of the sound in calm air is superposed by the velocity components of an airflow in the direction of the wind.

A wind velocity component in the propagation direction of the sound supports the speed of propagation; i.e. it increases it while a wind velocity component against the propagation direction reduces the speed of propagation.

The propagation speed resulting from superposition leads to different propagation times of the sound at different wind velocities and directions over a fixed measurement path.

As the speed of sound greatly depends on the temperature of the air, the propagation time of the sound is measured on each of the two measurement paths in **both** directions. This rules out the influence of temperature on the measurement result.

By combining the two measuring paths, which are at right angles to each other, the measurement results of the sum and the angle of the wind, velocity vector are obtained in the form of rectangular components.

After the rectangular velocity components have been measured, they are then converted to polar coordinates by the μ -processor of the anemometer and output as a sum and angle of wind velocity.

FINAL

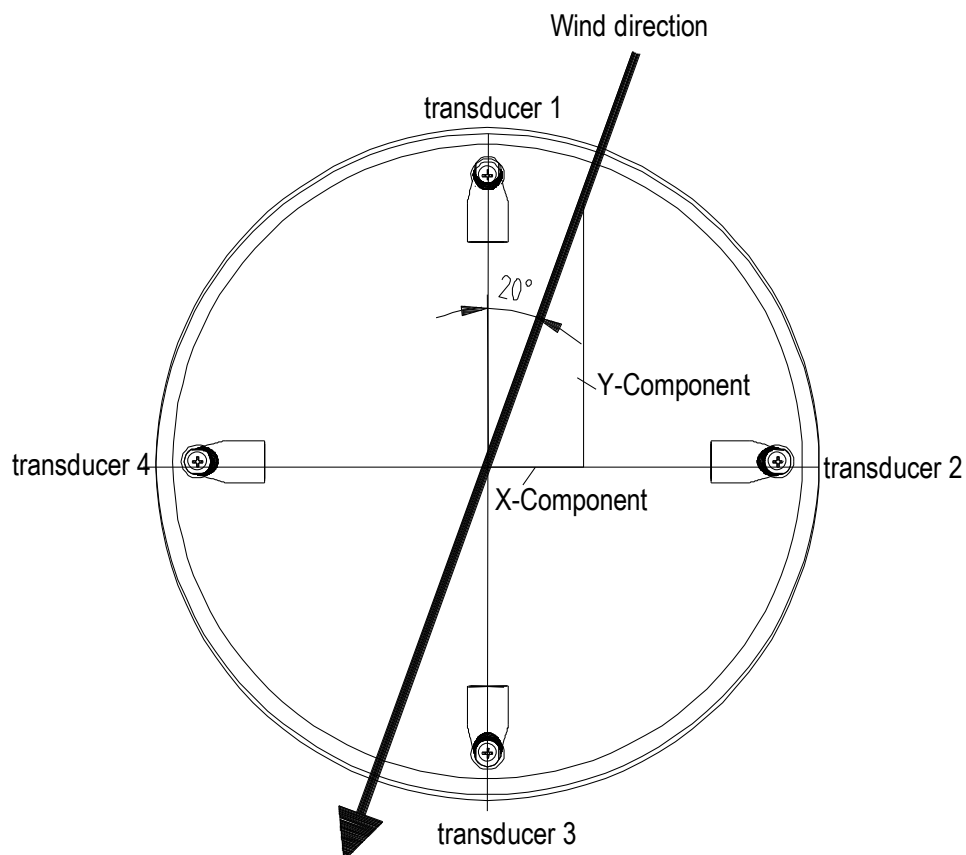

3.2 Measuring principle: Acoustic virtual temperature

The thermodynamic interrelationship between the propagation velocity of sound and the absolute temperature of the air is defined by a root function. The sound velocity is also more or less independent of the air pressure and only depends on the absolute air humidity to a minor extent. This physical interrelationship between sound velocity and temperature is ideal when measuring the air temperature as long as the chemical composition is known and constant.

The levels of gases in the atmosphere are constant and with the exception of water vapour content vary at most by a few 100ppm (CO₂) even over lengthy periods.

Determination of gas temperature via its sound velocity is performed directly from measurement of its physical properties without the step of thermal coupling of this gas to a sensor, which would otherwise be necessary.

Remark:

Due to warming of the instrument by solar radiation or heating activity the measuring value can be considered only conditionally as real measuring value, particularly at low wind velocities.

3.3 Measuring principle: Air pressure

The air pressure is measured via an MEMS sensor, basing on a piezo-resistive technology. The sensor is situated on the pc-board.

3.4 Heating

For many applications the continuous output of real measuring data of wind velocity and direction is an essential requirement to the measurement system even under meteorological extreme conditions such as icing situations.

The ultrasonic compact is, therefore, equipped with a sophisticated heating system which keeps a temperature of above +5°C on all outside surfaces, that might disturb the acquisition of run time data by ice formation.

Among the heated outside surfaces there are the base plate, sensor receiving sockets of the ultrasonic transducers, cover plate, and the ultrasonic transducer.

Please pay attention to the fact that the weakest link in the chain determines the complete functionality. Instruments, which heat only parts of the construction, hardly show advantages over completely unheated devices in icing situations.

The Ultrasonic Compact is capable to generate measuring data with high accuracy even in unheated condition with temperatures of up to below -40°C. There is no temperature dependency of the measuring data quality. The heating is necessary only for preventing icing formation at the instrument construction, so that possible disturbances of the run time acquisition can be avoided.

The heating system with a total maximum power of 250 W avoids effectively icing according to the in-house icing standard THIES STD 012002.

Thus, icing is safely avoided, for example, at a temperature of -20° up to a wind velocity of 10 m/s.

Functionality:

Heating foils and transistors are activated by a temperature sensor at an appropriate position inside the housing via a two-level-controller, thus providing for a constant temperature at the outside surfaces of approx. +5°C. That means, that the total heating power is activated until the required temperature is reached, and is alternately switched on and off (two-level-control) with a hysteresis of approximately 1Kelvin.

The necessary integral heating power depends on the thermal coupling to the surrounding air and thus to the wind velocity.

With moderate weather conditions the maximum heating power can be pre-selected in several stages.

See also description of parameter HT (heating) and HP (heating power).

4 Preparation for operation

Attention:

The working position of the anemometer is vertical (North arrow on the top).

During installation, de-installation, transport or maintenance of the anemometer it must be ensured that no water gets into the bottom and connector or cable gland of the anemometer.

When using a lightning rod take care that it be installed in a angle of 45° to a measuring transducer; otherwise there will be deviations in the measured values.

4.1 Selection of installation site

As described above, the ultrasonic anemometer transmits sound packages required to measure the propagation speed. If these **sound packages** meet surfaces that reflect sound well, they are thrown back as an **echo** and can may result in **incorrect measurements** under unfavourable conditions.

It is therefore advisable to install the ultrasonic anemometer at a **minimum distance of 1 metre to objects in the measuring level**.

In general, wind meters should register wind conditions over a wide area. To obtain comparable values when measuring the ground wind, measurement should be performed at a height of 10 metres above even and undisrupted terrain. Undisrupted terrain means that the distance between the wind transmitter and the obstruction should be at least ten times the height of the obstruction (s. VDI 3786, sheet 2). If it is not possible to comply with this provision, the wind meter should be installed at a height at which measured values are influenced by obstructions located in the vicinity to the least possible extent (approx. 6 - 10 m above the interference level). On flat roofs the anemometer should be installed in the middle of the roof and not at the edge to thus avoid any preferential directions.

The ultrasonic-anemometer has an electro-magnetic compatibility, which is far in excess of the required standard threshold value.

Within the complete frequency range, required by standard, electro-magnetic fields with 20 V/m (capacity of the test transmitter) could not affect the measuring value acquisition of the instrument.

In case you intend to install the instrument at transmitter masts or other sources of strong electro-magnetic radiation, where the local field strength is far above the standard threshold value, please contact the manufacturer.

4.2 Installation of anemometer

Proper installation of the ultrasonic anemometer is carried out using a tube socket R1½" (Ø 48.3 mm) and minimum 25 mm in length. The inside diameter of the pipe socket must be at least 25 mm as the ultrasonic anemometer is electrically connected from below. After connection the ultrasonic anemometer is fitted on the tube or mast socket. The north arrow of the instrument must be aligned to north (see chapter 3.3). The instrument is fixed to the shaft with the four Allen screws (SW 4 mm).

4.3 Alignment to north

For the exact determination of the wind direction the anemometer must be mounted with **north alignment** (geographical north). To align the anemometer, the **north arrow must point to north** (true north). To do so, select a conspicuous feature of the landscape to the north or south with a compass and turn the mast or anemometer until the north arrow indicates to the true north.

When aligning the instrument to north using a compass, the magnetic variation (= deviation in direction of compass needle from true north) and local interfering magnetic fields (e.g. iron parts, electric cables).



Alignment of the Anemometer on a Ship

- The benchmark for the anemometer is the roll-axis of the ship, whereat the **bow** is assigned to “0” (North).
- When aligning the anemometer on another moving objects (for ex. vehicles, wind generator etc.) this procedure can be applied, as well.

In the bottom of the anemometer stand there is a **north- drilling**. The north- drilling serves for the use of a so-called Mast- adaptor with bolt. The mast- adaptor is not included in delivery.



4.4 Electrical Installation for Ultrasonic Anemometer

The ultrasonic anemometer is equipped with a plug for electrical connection. A coupling socket (mating) is included in delivery. It is located in the lower part of the transport packing.

4.4.1 Cables, Cable preparation, Connector Installation

For pin assignment please refer to supplement „factory settings“. Examples see chapter 3.4.2.

The cable must have the following properties:

8 cores; 0,5 to 0,75 mm² core cross-section for supply ; min. 0,14 mm² core cross-section for data communications ; 7 - 8 mm cable diameter, resistant to ultraviolet rays, overall shielding.

Caution:

The cable to be connected must be at least the operating voltage class 01 correspond HAR (100V).

Remark:

Optionally, a completely converted connecting cable can be included in delivery for the ultrasonic-anemometer (see accessories).

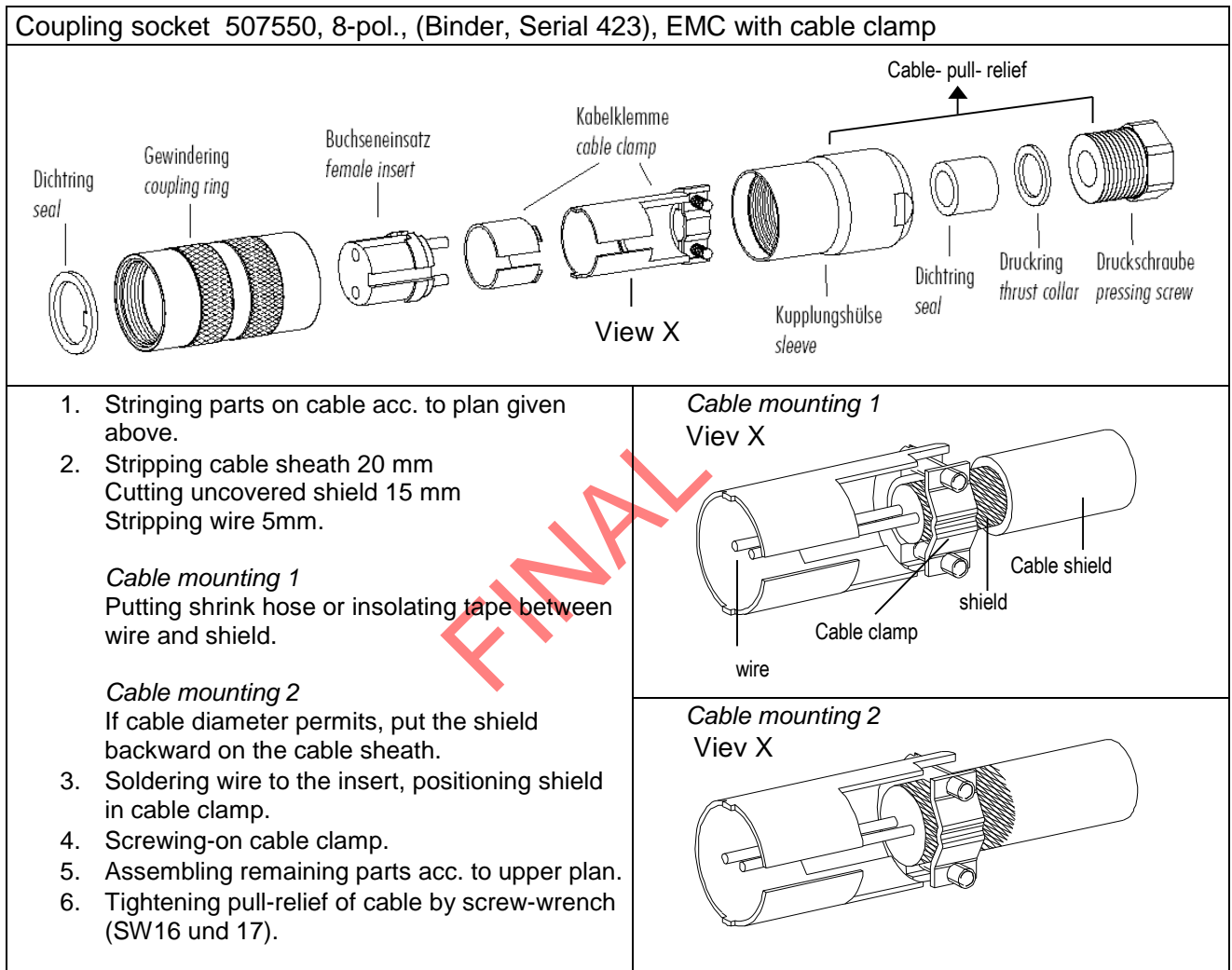

Figure 1: Connector installation

4.4.2 Connector Pin Assignment (Examples of Function)

Remark:

- For exact allocation of function please refer to supplement “Factory Settings”
- The pins 1 – 6 (incl.) are galvanically isolated from the supply voltage and from housing.

• Serial Interface, Full-duplex			View of solder terminal of coupling socket
Pin	Allocation	Function	
1	RXD-	Serial interface	
2	TXD-	Serial interface	
3	CONTROL	Function programmable	
4	RXD+	Serial interface	
5	TXD+	Serial interface	
6	AGND	Analogue ground	
7	24V AC/DC nominal	(-) Voltage supply	
8	24V AC/DC nominal	(+) Voltage supply	
⊥	Shield		

• Serial Interface, half-duplex and analogue outputs			View of solder terminal of coupling socket
Pin	allocation	Function	
1	WG	Analogue output wind speed	
2	TXD- / RXD-	Serial interface	
3	CONTROL	Function programmable	
4	WR	Analogue output wind direction	
5	TXD+ / RXD+	Serial interface	
6	AGND	Analogue ground	
7	24V AC/DC nominally	(-) Voltage supply	
8	24V AC/DC nominally	(+) Voltage supply	
⊥	Shield		

* reverse-polarity protected

FINAL

5 Maintenance

As the instrument does not have moving parts, i.e. is not subject to wear during operation, only minimal servicing is required. The instrument is subject to natural pollution, the level of pollution depends on the location. If necessary the instrument and the sensor surfaces can be cleaned from soil. Cleaning can be carried out as required using non-aggressive cleaning agents in water and a soft cloth during routine checks.

Attention:

During storage, installation, de-installation, transport or maintenance of the anemometer it must be ensured that no water gets into the instrument stand and plug of the anemometer.

6 Calibration

The ultrasonic anemometer does not contain any adjustable components such as electrical or mechanical trimming elements. All components and materials used show invariant behaviour in terms of time. This means that no regular calibration is required due to ageing. Errors in measured values can only be caused by coarse mechanical deformation of the instrument and associated changes in measurement path lengths.

The acoustic-virtual temperature can be used to check the effective-acoustic measurement path length. A change of approx. 0.3% in the measurement path length and thus a measuring error of approx. 0.3% for the wind velocity corresponds to a deviation in the virtual temperature of 1 K at 20°C; there is a measuring error of approx. 1% for the wind velocity with a deviation of acoustic-virtual temperature of approx. 3,4 K.

In the event of any change in the measurement paths of the anemometer the manufacturer should be consulted regarding recalibration.

Important:

Mechanical damages with deformation of the instrument might lead to measuring value errors.

7 Warranty

Damage caused by improper handling or external influences, e.g. lightning, do not fall under the warranty provisions. The warranty entitlement expires if the instrument is opened.

Important:

The ultrasonic anemometer must be returned in the original packaging as the warranty entitlement otherwise expires with mechanical damage, e.g. deformation of measuring arms.

8 Functional description

The functioning of the ULTRASONIC instrument is described below. Due to the limited number of plug connections some functions exclude the simultaneous operation with other functions. Such dependency is described in each case. There are also restrictions regarding the functional definition of the cable connector. This is due to the double assignment of individual PINs.

8.1 Serial communication

The ULTRASONIC provides an RS485 / RS422 interface for serial communication. It can be operated either in full or half duplex mode and at different baud rates.

A standard terminal program, for ex., can be used for communication with the ULTRASONIC. With a Windows-based operating system Hyper Terminal is included in the scope of supply.

In case that it is not available, it can be installed subsequently, if required.

When starting the ULTRASONIC, the firmware version, the date of writing the firmware, the serial number of the instrument, the system time, the instrument ID as well as the duplex mode of the serial interface are output.

Output is carried out with last set und stored baud rate:

Example:

```
-----  
THIES-ULTRASONIC-COMPACT  
Version: 2.20  
Mar 05 2014 / 08:14:29  
Serial-No.: 000000000  
System-Time: 14:19:29  
System-ID.: 00  
Serial-COM: 4-wire RS485  
-----  
Help: 00HH<CR>  
-----
```

The example shows that the ULTRASONIC operates with the instrument IC 00 in full-duplex mode.

8.1.1 Duplex mode

Duplex mode decides the type of physical connection of the serial interface. In full duplex mode the send and receive signals are each transmitted via separate pairs of cables. This means it is possible to send and receive signals at the same time.

In half duplex mode transmission of the send and receive signals is via the same pair of cables in the time division (successively) (: see **Command DM**).

For a bus operation in the half-duplex-mode (RS485), where the ULTRASONIC, in general, is operated as “slave”, it is necessary to switch the line-transmitter into the “high-impedance-state” during the intermission, so that the replies of the other bus parties are not suppressed.

It might be important with point-to-point-connections in the full-duplex-mode (RS422), depending on the disturb-ratio on the communication lines, that the line-transmitter remains active during the intermissions. So, a maximum differential input level leads to a maximum signal/noise ratio.

A half-duplex-mode can be selected via the **Command DM** (duplex mode). With this mode, on principle, the line-transmitter is switched on only when sending. For the full-duplex-operation there are two modes: one for bus operation (RS485), where the line-transmitter is controlled as in half-duplex mode, and another one (RS422), where the line-transmitter remains active even in case of reception. See **Command DM**.

For the ULTRASONIC there are restrictions on the parameter combination or function of the terminals depending on the transmission type selected. Due to the limited number of plug connector contacts multiple assignment of the connections are necessary. The following table shows the functional options for the modes full and half duplex.

Full duplex mode	Half duplex mode
Bus mode possible (RS 485, DM=1) Bus mode not possible (RS 422, DM=2)	Bus mode possible (RS 485, DM=0)
No output of analogue values to PIN RXD- and RXD+	Output of analogue values possible at PIN RXD- and RXD+
Heating control via PIN CONTROL possible	Heating control via PIN CONTROL possible

Table 1: Restrictions in full and half duplex mode

8.1.2 Response Delay

With the serial communication please take into consideration that the ULTRASONIC responds immediately to arriving telegrams. The response time of the instrument is in the lower range of milliseconds. Possibly, the delay between receiving signal and sending signal might be too short for some interface converters. It is possible that, within this time period, the interface converter has not yet switched over from the mode 'sending' to the mode 'receiving'. This might lead to absurd telegrams.

In order to avoid this effect, the ULTRASONIC has the parameter RD (response delay). With this parameter the response is additionally delayed, on receipt, by the selected value in milliseconds. The setting of the parameter on state of delivery depends on the instrument number.

8.1.3 General telegram structure

For serial communication the ULTRASONIC has a fixed telegram format, which also permits communication in bus mode. It has the following form:

NNBB<cr> <cr> stands for Carriage return (Enter key)

for a data enquiry or

NNBBPPPPP<cr> <cr> stands for Carriage return (Enter key)

for a parameter change.

The individual letters have the following meaning:

- NN: Two-digit ID of the ULTRASONIC. It can be selected in the range from 00 to 99. The presetting is the ID '00': see also **Command ID**.
- BB: Two-position command. A complete list can be found in section Command list.
- PPPPP: The parameter input is always left-justified and can range from 0 to 5-digit value.

Example:

The telegram number 2 is to be inquired. The respective command is:

00TR2<cr> <cr> stands for Carriage return (Enter key)

alternatively possible also:

00TR00002<cr>

The prerequisite in this example is that the ULTRASONIC ID has the value '00'.

Example:

With the command

00BR<cr> <cr> stands for Carriage return (Enter key)

the selected data record for the baud rate is returned.

!00BR01152 stands for 115200 Baud

Remark:

The receiving buffer of the ULTRASONIC can be cleared by sending a carriage return <CR>. If the ULTRASONIC possibly has invalid characters in the receiving buffer, this buffer can be processed by sending a carriage return. In this case, it is advisable to send a carriage return at the beginning of the telegram, for example: <CR>00TR00002<CR>

8.1.4 Saving of the ULTRASONIC Parameters

After a change in parameter by the user- or administrator-key, the ULTRASONIC must be reset into the locked status by the command „00KY0“ (Key „00000“). (In this case the ULTRASONIC ID has the value „00“).

Only by resetting the key the parameters are saved permanently also beyond a restart.

When restarting the ULTRASONIC without prior saving all changed parameters get lost; therefore, it is recommendable to save all important parameters after termination of entry by resetting the key (00KY0).

8.1.5 Return values of ULTRASONIC

After a valid command has been input, the ULTRASONIC sends acknowledgement, e.g. acceptance of the parameter or output of a data telegram.

For a standard command the response starts with a '!', followed by the ID and the parameter value.

If the input command is TR or TT, the ULTRASONIC transmits a data telegram as the response.

8.1.6 Access Mode

For configuration the ULTRASONIC has a set of commands, which determine behaviour in terms of the propagation time. The commands are broken down into three levels:

- Query Mode
- User mode
- Configuration mode

Enquiry mode (“READ ONLY“):

This mode comprises commands, which do not influence the parameters of the ULTRASONIC. They include for example, output of the system status and interrogation of the data telegram with TR.

User mode (“USER“):

This mode comprises commands, which affect the behaviour of the ULTRASONIC. These parameters can be changed by the user. The system behaviour of the instrument is changed with these commands. This group of commands includes e.g. settings for output scaling and averaging

Configuration mode (“ADMIN“):

This mode comprises commands, which are factory-set for the delivery status.

To distinguish between commands of the three groups when parameterising the ULTRASONIC the instrument is equipped with an access key KY. Inputting of the key accesses the individual levels. Access to commands at a higher level includes access to commands at a lower level.

Access key	Response from ULTRASONIC	Command level
00KY00000	READ ONLY !00KY00000	Query mode (preset)
00KY00001	USER ACCESS !00KY00001	User mode
00KY04711	ADMIN ACCESS !00KY04711	Configuration mode

Table 2: Access key for different command levels

After the access key has been changed, the ULTRASONIC transmits a response, which contains not only the parameter input but also the access mode.

After parameters have been changed with the key '00001' or '04711', the ULTRASONIC must be reset to the initial position with the command 00KY00000, so that the parameter are saved. (see also chapter 9.1.4).

In case of power supply interruption the instrument is reset automatically to the query mode.

Example:

```
00KY1          switch into „USER ACCESS“ mode
!00KY00001    response from ULTRASONIC
Setting rights -> USER      response from ULTRASONIC
```

```
00AV5          command for changing averaging time frame
!00AV00005    response from ULTRASONIC
New Averaging time frame: 5      response from ULTRASONIC
00KY0          command for the „READ ONLY“ mode
!00KY00000    response from ULTRASONIC
Setting rights -> READ ONLY      response from ULTRASONIC
Configuration saved.            response from ULTRASONIC
```

8.1.7 Baud rate

The baud rate is used to select the transmission speed via the serial interface. The parameter range is from 1200 baud to 115,2 kBaud.

The reprogramming of the baud rate by command BR affects at once temporarily the ULTRASONIC. After the dispatch of a command, the user program used must be set to the corresponding baud rate. Only after resetting into the query mode (READ ONLY) the baud rate is saved permanently. Thus, an accidental changing of the baud rate by switching on/off, the ULTRASONIC can be revoked. (see also chapter 9.1.4)

Example:

The baud rate is to be changed to 115200 baud:

```
Command:
00KY4711      Command for access allowance
!00KY04711    response from ULTRASONIC
Setting rights -> ADMIN      response from ULTRASONIC
00BR1152      Command for changing the baud rate
!00BR01152    response from ULTRASONIC
Now the interface baud rate must be changed to 115200!
00KY0         backspace into the „READ ONLY“ mode
!00KY00000    response from ULTRASONIC
Setting rights -> READ ONLY  response from ULTRASONIC
Configuration saved.        response from ULTRASONIC
```

8.1.8 Instrument ID

The instrument ID specifies the address to which the ULTRASONIC is to respond during serial communication. The instrument ID lies in the range from '00' to '99'. The preset ID is '00'. Every telegram from the ULTRASONIC starts with the ID set. Under certain conditions this provides for bus mode: see **Bus mode**.

The instrument ID „99“ is a universal address to which all ULTRASONICs respond.

The ID is reprogrammed with the command 'ID'. The new ID of the ULTRASONIC is specified as the parameter. After the change has been made, the ULTRASONIC immediately responds to the new address. (s. a. chapter 9.1.4).

Example:
 00KY4711 Command for access allowance
 !00KY04711 response from ULTRASONIC
 Setting rights -> ADMIN response from ULTRASONIC

00ID00004 Changing of IC into address 4
 !00ID00004 response from ULTRASONIC

The ULTRASONIC responds now to the now ID ,04'. For permanent ID changing see chapter 9.1.4.

04AV Query of the averaging time by new ID
 !04AV00005 Return of averaging time

8.1.9 Bus mode

The concept of ID-based communication allows the ULTRASONICs to be operated in a bus system. The prerequisites for this are:

- half duplex mode
- different IDs of the individual bus users
- master-slave structure, i.e. there is a device in the bus (control, PC ...) that performs cyclic enquiry of the data of the individual ULTRASONICs and possibly parameterises the ULTRASONICs.

In bus mode there are no restrictions on parameterizability.

A firmware-update, however, is not possible in half-duplex mode.

A station can also be provided with a new program in bus mode for a specific purpose. With an update a program update must be performed for every ULTRASONIC.

In bus mode it is recommended not using an ULTRASONIC with the ID '00' as this ID is reserved for devices that are integrated in the bus for the first time.

8.2 Analogue outputs

As an additional option the analogue outputs WV/RXD- and WD/RXD+ offer the possibility of outputting the wind velocity and wind direction as analogue values both as a voltage and power value. Moreover, a starting offset of the power- resp. voltage output is selectable. This realizes the interfaces 4..20mA resp. 2...10 V. See the table for the possible combinations.

	Parameter SC=0	Parameter SC=1
Parameter AO=0	No output	No output
Parameter AO=1	WG: 0..10V, WR: 0..10V	WG: 2..10V, WR: 2..10V
Parameter AO=2	WG: 0..20mA, WR: 0..20mA	WG: 4..20mA, WR: 4..20mA
Parameter AO=3	WG: 0..20mA, WR: 0..10V	WG: 4..20mA, WR: 2..10V
Parameter AO=4	WG: 0..10V, WR: 0..20mA	WG: 2..10V, WR: 4..20mA

Table 3: Config. of analogue outputs WV/RXD- and WD/RXD+ with parameters AO a. SC

8.2.1 Scaling of analogue wind velocity

With the analogue wind velocity the user has the option of specifying the velocity for the terminal value of the measuring range with the command AR. In the preset value the scaling is 0..60m/s: see **Command AR**.

The terminal scaling value is specified in m/s. For example the command 00AR00030 scales the analogue output range of 0..30m/s wind velocity. With a setting of 2..10V this results in the following:

WV =0m/s -> 2V and
WV=30m/s -> 10V

8.2.2 Correction to North

The command NC is used to adjust the measured angle of the wind direction into positive direction by an angle offset. This entered value is added to the measured angle of the wind direction internally in the instrument. If the resulting value is greater than 360°, 360° is subtracted from the corrected angle value. The setting is then used when the ULTRASONIC with its north sensor could not exactly be aligned to north, and this error angle must be corrected electronically afterwards. Also see here **Command NC**.

The wind direction is reset at a calculated wind velocity of < 0,1m/s .

The wind direction 0° is reserved for the calm.

Unlike the calm, the exact wind direction north, corresponding to 0°, is output as 360° at wind velocities >0,1 m/s.

8.3 Instantaneous values and output of raw measured values

The output of instantaneous values is generally a special case. Due to the high acquisition speed for the measured values averaging of the data is sensible in most cases. If instantaneous values are to be output, averaging must not be switched on. The parameter AV should be set to '0': see **Command AV**.

The OR parameter is used to adjust the output rate with independent output. With a value of '0' a telegram is output whenever the control line is operated. See also command TG.

8.3.1 Averaging

Given the high data acquisition rate averaging is to be recommended in most cases. The averaging period is freely selectable from 600 ms to 100 minutes within wide limits. See also **'Table 5'** under **'Command AV'**.

It is a basic rule that only valid values are written to the averaging puffer. The size of the buffer is not determined by the number of data records but by the difference in the time stamp between the first and last data record. As a result any missing measured values do not influence the averaging result. The content level of the averaging buffer is shown in the status value of the ULTRASONIC. It is the ratio between the memory actually occupied and the maximum required memory (calculated value). Output is performed in eight or 16 steps: see Status information.

The Ultrasonic 2D compact incorporates two different practical procedures for averaging:

- one **procedure for generating vectorial mean values** and
- one **procedure for generating scalar mean values**

These different procedures can be selected for averaging wind velocity as well as wind direction depending on the actual application.

Vectorial averaging involves the wind direction for averaging of the wind velocity, and wind velocity for averaging of the wind direction.

Both averaged variables, wind velocity and wind direction, thus each undergo evaluation with the other measured variable.

This averaging procedure is very suitable e.g. for measuring and evaluating the propagation of pollutants.

Scalar averaging averages both variables, wind velocity and wind direction, independently of each other.

This averaging procedure leads to comparable results with mechanical wind velocity and wind direction pickups.

The scalar averaging procedure is suitable e.g. for location analysis for wind turbines where only the wind vector variable relevant for the generation of energy is of interest and not its direction.

The vectorial and scalar procedure can be used within one output telegram independently of the wind velocity and wind direction.

For this purpose one of the four possible combinations is selected using the Command **AM** as for **Average Method**.

Command for selection of averaging procedure:

AM00000 Vectorial averaging of velocity and direction

AM00001 Scalar averaging of velocity and direction

AM00002 Scalar averaging of velocity and vectorial averaging of direction

AM00003 Vectorial averaging of velocity and scalar averaging of direction

8.4 Serial Data Output

The transmission of data via the RS485 interface is known as serial data output. Two modes are available for data transmission:

- Independent transmission of data
- Transmission of data via interrogation telegram

Independent transmission of the data is selected using the command 00TT000XX, with XX standing for the relevant telegram number. In this case the ULTRASONIC transmits its data cyclically in the repeat rate selected with the parameter OR.

8.4.1 Data Query

The command TR is used for data enquiry via the ULTRASONIC. The command has no access protection. After processing the command the instrument sends back the appropriate response telegram. The time between the last character in the request telegram and the first character in the data telegram is < 0.5ms.

The user-defined telegram and the telegrams, as for the definitions described under '**Fixed telegram formats**', are available as data telegrams.

8.4.2 Independent telegram output

Independent telegram output is selected using the command TT. After a valid telegram type has been input, the ULTRASONIC independently transmits the data telegram selected. The transmission interval is set in ms using the command OR. The telegram is transmitted every 100ms as standard. If the baud rate selected does not allow the output cycle to be observed (the time for data transmission is greater than the interval time), it is possible that telegram output cannot be carried out.

Note:

In the half duplex mode (see command DM) the independent telegram output starts only 10s after the last command, or 20 s after the re-start. Thus, the ULTRASONIC can be re-programmed or resp., the new configuration can be saved.

8.4.3 Fixed telegram formats

A number of predefined telegrams are available to for the independent output of telegrams (**Command TT**) and data request (**Command TR**). The detailed structure is described in 'Appendix 1 Predefined data telegrams'. A reference list of telegram formats can be found in '**Table 4**'.

Telegram name	Telegram number	Telegram structure
VD	00001	(STX)VV.V DDD*CC(CR)(ETX)
VDT	00002	(STX)VV.V DDD TTT.T SS*CC(CR)(ETX)
VD2	00003	(STX)VVV.VV DDD.D*CC(CR)(ETX)
NMEA V 2.0	00004	\$WIMWV,DDD.D,R,VVV.V,X,A*CCR)(LF)
Vx, Vy, VT	00007	(STX)+VV.V;+VV.V;+TT.T;SS;CC(CR)(ETX)
VDM	00008	(STX)ID VVV.VV DDD.D SS MM*CC(CR)(ETX)
VDPM	00009	(STX)ID VVV.VV DDD.D PPPP.P SS MM*CC(CR)(ETX)
Scientific telegram	00012	See appendix (chapter 10)

Table 4: List of predefined data telegrams

Declaration:

- V: wind velocity (see **Command OS**)
- D: wind direction
- P: air pressure (optional)
- M: Voltage Supply Monitoring
- T: temperature
- S: status byte
- C: Check sum (EXOR link)
- X: identifier for scaling of wind velocity (K, N, M, S = km/h, Knots, m/s, mph)

8.4.4 Generation of check sum

The check sum is the result of the byte wise EXOR link of the bytes output in the telegram.

The EXOR link encompasses all bytes between the telegram start character "STX", or "\$" with the NMEA telegram and the byte "*" as the identifying character for the start of the check sum. The bytes "STX" or "\$" and "*" are thus not taken into account for calculation of the check sum! In the telegram 7 the last byte ";" before the check sum is stated representatively for the byte "*,", and is thus not taken into account for calculation of the check sum!

8.4.5 Status information

In the ULTRASONIC two different status bytes are available:

- extended status information (scientific telegram only, see also "TT12")
- THIES status

The THIES status is derived from the extended status information. The structure of the status values is described below.

8.4.5.1 Extended Status Information

The extended status is structured bit wise. The individual bits in the status value have the following meanings:

Bit number	Function	Description	
Bit 0	General malfunction	Averaging time < 30sec preset see „ET“ Command Error Timeout	An error is output when no new measured value can be determined during a period of 30sec.
		Averaging time >= 30sec preset see „ET“ Command Error Timeout	An error is output when the averaging buffer includes no valid value.
Bit 1	Heating enabled	Is one when heating control is activated.	
Bit 2	Heating status	Is one when bottom heating is consuming power.	
Bit 3	Reserved	Is always zero.	
Bit 4	Static malfunction	Is set when a static malfunction has occurred, e.g. lasting violation of VT, no measured values. (> 1min)	
Bit 5 .. bit 7	Reserved	Is always zero.	
Bit 8	Used averaging memory	Specifies the averaging memory occupied. Bit 0 to bit 3 indicate the filling level of the averaging buffer in binary format. 0: Buffer 0 < x ≤ 1/16	
Bit 9			
Bit 10			

Bit 11		1: Buffer $1/8 < x \leq 1/8$ filled 2: Buffer $1/8 < x \leq 3/16$ filled 3: Buffer $3/16 < x \leq 1/4$ filled 4: Buffer $1/4 < x \leq 5/16$ filled 5: Buffer $5/16 < x \leq 3/8$ filled 6: Buffer $3/8 < x \leq 7/16$ filled 7: Buffer $7/16 < x \leq 1/2$ filled 8: Buffer $1/2 < x \leq 9/16$ filled 9: Buffer $9/16 < x \leq 5/8$ filled 10: Buffer $5/8 < x \leq 11/16$ filled 11: Buffer $11/16 < x \leq 3/4$ filled 12: Buffer $3/4 < x \leq 13/16$ filled 13: Buffer $13/16 < x \leq 7/8$ filled 14: Buffer $7/8 < x \leq 15/16$ filled 15: Buffer $15/16 < x \leq 1$ filled
Bit 12	Reserved	
Bit 13	Flag restart	Is reset to zero in the first output-telegram after restart.
Bit 14..bit15	Reserved	Is always zero
Bit 16..bit31	Reserved	Is always zero.

FINAL

8.4.5.2 THIES Status

The THIES status is structured bit wise. The individual bits in the status value have the following meanings:

Bit number	Function	Description	
Bit 0	General malfunction	Averaging time < 30sec preset see „ET“ Command Error Timeout	An error is output when no new measured value can be determined during a period of 30sec.
		Averaging time >= 30sec preset see „ET“ Command Error Timeout	An error is output when the averaging buffer includes no valid value.
Bit 1	Used averaging memory	Specifies the averaging memory occupied. Bit 1 to bit 3 indicate the filling level of the averaging buffer in binary format. 0: Buffer $0 < x \leq 1/8$ 1: Buffer $1/8 < x \leq 1/4$ filled 2: Buffer $1/4 < x \leq 3/8$ filled 3: Buffer $3/8 < x \leq 1/2$ filled 4: Buffer $1/2 < x \leq 5/8$ filled 5: Buffer $5/8 < x \leq 3/4$ filled 6: Buffer $3/4 < x \leq 7/8$ filled 7: Buffer $7/8 < x \leq 1$ filled	
Bit 2			
Bit 3			
Bit 4	Plausibility on	Is set when the plausibility is on.	
Bit 5	Static malfunction	Is set when a static malfunction has occurred, e.g. lasting violation of VT, no measured values. (> 1min)	
Bit 6	Heating enabled	Is one when heating control is activated.	
Bit 7	Heating status	Is one when bottom heating is consuming power.	

8.4.5.3 VDM/VDPM Telegram Status Byte

This status is structured bit wise. The individual bits in the status value have the following meanings:

Bit number	Function	Description	
Bit 0	General malfunction	Averaging time < 30sec preset see „ET“ Command Error Timeout	An error is output when no new measured value can be determined during a period of 30sec.
		Averaging time >= 30sec preset see „ET“ Command Error Timeout	An error is output when the averaging buffer includes no valid value
Bit 1	Valid Data Check	Is set when the plausibility check is set to "On".	
Bit 2	Heater Circuit Enabled	Is set when the Heating Circuit is Enabled.	
Bit 3	Heating Status	Is set when bottom heating is dissipating power.	
Bit 4	Heater Over Current Warning	Is set when the heater current exceeds the max. range.	
Bit 5	Heater Thermistor Open Circuit Failure	Is set when the heater circuit value isn't inside of $-50^{\circ}\text{C} \dots +80^{\circ}\text{C}$ because of open circuit.	
Bit 6	Unit Internal Temperature High Warning	Is set when the temperature of the unit exceeds $+60^{\circ}\text{C}$.	

8.4.5.4 Voltage Supply Monitoring Byte

The Sonic Voltage is calculated in the following way:

Byte Range(Hex): 00...ff

$V_{\text{supply}} = \text{Value} * 0.25V$

Example: Voltage Byte = 64(hex) $V_{\text{supply}} = 100 * 0.25V = 25.0V$

Note: At AC supply the peak value will be shown, not RMS.

8.5 Behaviour of Instrument under extreme Conditions of Measurement Value Acquisition

The ULTRASONIC is equipped with a highly effective internal fault detection and correction system. This allows it to detect incorrect measured values using the history and to correct them where possible. It cannot however be ruled out that the ULTRASONIC will get into a situation in which the acquisition of new data is impossible. In this case the error bits are set in the status values and a defined value possibly output at the analogue outputs.

It is a basic rule that the measured values output are always valid and can be interpreted by the target system (unless a specific error telegram is output in the in the case of error). In the case of error might happen that the data become 'too old', i.e. they are not updated over a certain time and freeze. In this case the error bits are set in the status byte and the analogue outputs are set to a defined value. If a special error telegram is defined with a serial telegram, this is output.

FINAL

8.5.1 In the event of error

Error may occur under the following circumstances:

Averaging time < 10sec (parameter AV)	An error is output when no new measured value can be determined during a period of 10sec.
------------------------------------------	-------------------------------------------------------------------------------------------

8.5.2 Behaviour of analogue outputs

If the analogue outputs are active, they are switched to the minimum or maximum value in the case of error. The parameter EI determines which of the two values is output: see **Command EI**.

8.5.3 Behaviour of telegram output

In the case of error the relevant error telegram is output. In parallel the error information is shown in the status byte: see **Fixed telegram formats**.

8.6 Output of all system parameters

Most parameters of the ULTRASONIC are stored internally in an EEPROM. The command SS can be used to output all stored parameters.

Before amending parameters it is recommended making a backup copy of existing settings and storing them in a text file: see also **Command SS**.

8.7 Enquiry about software version

The command SV is used to enquire about the software version. For further information see **Command SV**.

8.8 Forcing a restart

The command RS can be used to force a restart of the ULTRASONIC. The commands

00RS00001 <cr> quick restart (warm start)

00RS00002 <cr> restart by intentional releasing of the „WatchDog“ after approx. 12s

can be carried out only with ADMIN-rights, on this see KY-command

8.9 Energy-saving mode

Thanks to the sleep mode the ULTRASONIC can be operated in an energy-saving mode, see **Command SM**. In the sleep mode the heating is automatically turned off.

Alternatively the power supply of the ULTRASONIC can be completely switched off, and can be turned on again for the duration of the measurement acquisition (incl. telegram output) for approx. 100 ms (typically). In this case it is useful to activate the function “silent boot”.

Silent boot: Due to parameter 00HH00002 no restart report is output on activating the power supply of the ULTRASONIC, see **Command HH**.

For this application the heating of the ULTRASONIC should be completely turned off by command 00HT00000, see **Command HT**.

8.10 Plausibility

To identify incorrectly measured values the ULTRASONIC offers an internal plausibility check, which assesses measured values using the history. Incorrect measured values can be caused for example by heavy rainfall or foreign bodies in the measurement path.

If an incorrect measured value is identified, the ULTRASONIC sets its acquisition of measured values to the maximum speed. In this mode it is more likely to obtain a valid measured value in fault conditions (e.g. horizontal rain). A complete data record is now made every 12ms using all 4 sensors so that the ULTRASONIC generates approx. 80 measured values per second.

8.11 Online help

For a short description of commands the ULTRASONIC contains an Online help, which provides information about individual commands. The Help text for the command is returned by inputting the command and a '?'.

If the command

00?? <cr> <cr> stands for Carriage return (Enter key)

or

00HH <cr> <cr> stands for Carriage return (Enter key)

is input, the ULTRASONIC will list all commands with the relevant help.

Example:

Help with setting the baud rate is to be called up: see **Command BR**.

With the command

00BR?<cr> <cr> stands for Carriage return (Enter key)

the ULTRASONIC provides the following response:

Baud rate in baud per second

12:	1200 Baud
24:	2400 Baud
48:	4800 Baud
96:	9600 Baud
192:	19200 Baud
384:	38400 Baud
576:	57600 Baud
1152:	115200 Baud
2304:	230400 Baud
4608:	460800 Baud
9216:	921600 Baud

Only admin authorised!

9 Configuration of ultrasonic anemometer by customer

The Ultrasonic Anemometer 2 D compact is factory-set prior to delivery to the customer.

- Setting is described in the supplementary sheet "*Factory Setting*".
-

It is possible for the customer to alter the factory setting of the Ultrasonic Anemometer 2D or to adapt it to new requirements. Here it should be borne in mind that with a change in settings, the order number allocated at the factory can then no longer help with identification.

The Anemometer 2D can be configured via its serial data interface using commands.

see section:

- *Access mode*
- *Command list*

Any standard terminal program such as "Telix" or a Windows terminal program (e.g. Hyper Terminal, or "Tera Term") can be used for this purpose.

Recommendation:

After performing configuration please amend the supplementary sheet "Factory Setting" and also send in to the manufacturer in the event of maintenance or repair.

FINAL

10 List of Commands

	Command	Description
Command AD	<id>AD<para5>	Setting the delay time of individual measurement (Acquisition Delay)
Command AM	<id>AM<para5>	Setting of average mode.
Command AO	<id>AO<para5>	Analogue output mode
Command AR	<id>AR<para5>	Scaling of analogue wind velocity output (Analogue Range)
Command AS	<id>AS<para5>	Setting of the analogue outputs to specified values (Analogue Static)
Command AV	<id>AV<para5>	Average time frame
Command BR	<id>BR<para5>	Selecting the interface baud rate
Command BP	<id>BP<para5>	Selecting interface parity (Baud Parity)
Command BT	<id>BT<para5>	Switching on the RS485 bus termination
Command CS	<id>CS<para5>	Configuration Saving
Command DM	<id>DM<para5>	Duplex mode
Command DT	<id>DT<para5>	Date- and time stamp
Command EI	<id>EI<para5>	Analogue value in case of error (Error inversion)
Command ET	<id>ET<para5>	Time until a measured value error sets the generic error bit (Error Timeout)
Command HC	<id>HC<para5>	Heating Condition
Command HH	<id>HH<para5>	Output of help (Help, identical with: <id>??<para5>)
Command HP	<id>HP<para5>	Heating power
Command HT	<id>HT<para5>	Heating control
Command ID	<id>ID<para5>	ULTRASONIC ID
Command KY	<id>KY<para5>	Access mode (Key)
Command MD	<id>MD<para5>	Measurement interval (Measurement Delay)
Command NC	<id>NC<para5>	North correction
Command OR	<id>OR<para5>	Telegram Output rate
Command OS	<id>OS<para5>	Scaling of the wind velocity output (Output Scale)
Command PU	<id>PU<para5>	Connectable power source to control- line (Pull Up, max. 5V @ 5mA)
Command RD	<id>RD<para5>	Response delay
Command RS	<id>RS<para5>	Warm start ULTRASONIC (Reset)
Command RT	<id>RT<para7>	Setting of Real Time Clock (Real Time clock)
Command SC	<id>CO<para5>	Setting start offset of the analogue outputs (1V / 4mA)
Command SM	<id>SM<para5>	Energy saving mode (Sleep Mode)
Command SN	<id>SN<para8>	Outputs the Serial number
Command SS	<id>SS<para5>	System status
Command SU	<id>SU<para5>	Preparing a "software upload" (firmware update)
Command SV	<id>SV<para5>	Software version
Command TA	<id>TA	This order number for ex. 4.387x.xx.xxx
Command TG	<id>TG<para5>	Trigger characteristic (Trigger)
Command TI	<id>TI<para5>	Brief information to the telegram (Telegram Info)
Command TR	<id>TR<para5>	Telegram query (Transmit request)
Command TT	<id>TT<para5>	Independent telegram output (Telegram Transmission)
Command WD	<id>WD<para6>	Wind warning start and stop Delays
Command WW	<id>WW<para6>	Wind Warning thresholds

11 Command and description

Command AD

<id>AD<para5> Setting the delay time of individual measurement (Acquisition Delay)
 Access: Configuration mode (ADMIN)

Description: This command sets the time period from the beginning of a propagation time
 Measurement (TOF) up to the following TOF (repetition rate of TOF measurements)

Value range: 2..25
 Initial value: 3

Command AM

T <id>AM<para5> Setting of average mode.
Access: Configuration mode (ADMIN)

Description: This command can be used to select the type of averaging method. Averaging can be either vectorial or scalar: see also chapter **8.3.1**.

Parameter description:

- 0: vectorially averaged velocity and vectorially averaged angle
- 1: scalarly averaged velocity and scalarly averaged angle
- 2: scalarly averaged velocity and vectorially averaged angle
- 3: vectorially averaged velocity and scalarly averaged angle

Range of values 0..3
Initial value: 0

Command AO

<id>AO<para5> Analogue output mode
Access Configuration mode (ADMIN)
Description: Setting of mode for the output of the analogue wind direction (WD) and wind velocity (WV). With this command one can switch-over from power output to voltage output. It is either 0..20mA (0..10V) or 4..20mA (2..10V), see **Command SC**.
The parameter can only be change when operating mode half-duplex is selected see **Command DM**.

Parameter description:

- 0: off, analogue outputs are not used. The internal calculation and the output of the analogue values are completely switched off.
- 1: Voltage output for WV and WD
- 2: Power output for WV and WD
- 3: Power output for WV and voltage output for WD
- 4: Voltage output for WV and power output for WD
- 11: as parameter „1“, however with WD-range 0..540° special treatment
- 12: as parameter „2“, however with WD-range 0..540° special treatment
- 13: as parameter „3“, however with WD-range 0..540° special treatment
- 14: as parameter „4“, however with WD-range 0..540° special treatment

Value range: 0..4, 11..14
Initial value: 0

Command AR

<id>AR<para5> Scaling of analogue wind velocity output (Analogue Range)
Access: Configuration mode (ADMIN)
Description: Specifies the range used for scaling of the analogue wind velocity output. The standard ULTRASONIC scales the wind velocity as follows:
0..10V (2..10V) corresponds to 0..60m/s
It may however also be sensible to scale the wind velocity of 0..30m/s:
0..10V (2..10V) corresponds to 0..30m/s
The end of the measuring range is specified with this parameter. Specification is made in m/s.

Parameter description:

- 0..80: Specifies of the end of the measuring range of the wind velocity (WV).

If the command AR00045 is input for example, 10V or 20mA corresponds to a wind velocity of 45m/s.

Range of values 1..80
Initial value: 00060

Command AS

<id>AS<para5> Testing the analogue outputs (Analogue Static output)
Access: Configuration mode (ADMIN)
Description: By means of this command the analogue outputs of wind velocity and wind direction can be set to a required, fixed value.

Parameter description

00AS00225 Sets the analogue outputs to 22.5% of 10V = 2.25V
00AS10500 Sets the analogue outputs WV to 50% of 10V = 5V
00AS00000 Sets the analogue outputs to 0% of 10V = 0V
00AS Resets the analogue outputs to normal operation.

Prerequisite for the test is that the operation mode half-duplex is active in the ULTRASONIC, see **Command DM**.

Value range: 0..21000
Initial value: 0

Command AV

<id>AV<para5> Average time frame (Average)
Access: User mode
Description: This command can be used to specify the period over which the ULTRASONIC averages its measured values. Given the high measuring speed of up to 100Hz for the generation of a complete measured value set, the use of averaging is sensible in most cases.

Parameter description:

Parameter for AV	Selected averaging time
0	No averaging
1	Averaging over 100ms
10...1200	Averaging over 1...120,0s

Table 5: Adjustment of averaging periods with parameter AV

The averaging memory is designed as a sliding memory.
On start-up the data of the averaging memory are instantly valid. Averaging is performed immediately using the measured values available.

Value range: 0..1200
Initial value: 10

Command BP

<id>BP<para5> Defines the parity of the interface baud rate (Baud rate Parity)
Access: Configuration mode (ADMIN)
Description: Parameter 7: parity7E1 Parameter 8: parity 8N1

Value range: 7..8
Initial value: 8

Command BR

<id>BR<para5> Selecting baud rate
Access: Configuration mode (ADMIN)
Description: The ULTRASONIC communication can be used with different baud rates. The following baud rates are defined for BR:

Parameter description:

12:	1200 Baud
24:	2400 Baud
48:	4800 Baud
96:	9600 Baud
192:	19200 Baud
384:	38400 Baud
576:	57600 Baud
1152:	115200 Baud
2304:	230400 Baud
4608:	460800 Baud
9216:	921600 Baud

Table 6: List of baud rates with telegram BR

After the baud rate has been changed, the ULTRASONIC returns the value of the newly set baud rate in the previous baud rate, so that the command receipt remains visible.

When interrogating the baud rate using the command BR, the ULTRASONIC gives back the last programmed baud rate and the selected parity.
See also command BP.

Example: 00BR
!00BR00096
Actual Baud Rate-> 9600 8N1
Initial value: 96

Command BT

<id>BT<para5> Bus termination
Access: Configuration mode (ADMIN)
Description: Command for connecting a terminating resistor of approx. 120 ohm on the RS485 lines.

Parameter description:

0: bus termination off.
1: bus termination on.

Initial value: depending on instrument

Command CS

<id>CS<para5> Configuration saving
Access: Configuration mode (ADMIN)
Description: Command for saving the configuration without leaving the configuration mode.
Parameter: 1: configuration saving

Command DM

<id>DM<para5> Duplex mode
Access: Configuration mode
Description: Duplex mode decides the type of physical connection of the serial interface. In full duplex mode the send and receive signals are each transmitted via separate pairs of cables. This means it is possible to send and receive signals as required. In half duplex mode transmission of the send or receive signals is via the same pair of cables:
Depending on the setting there are restrictions on the function of the connector PINs of the ULTRASONIC, see **Command AO**.

It is only possible to switch from half duplex to full duplex mode with the following prerequisites:

- The PINs WG/RXD- and WR/RXD+ must not be selected as analogue outputs see **Command AO**.

Parameter description:

- 0: Half duplex mode (RS485, transmission drivers are switched off if no data sent.)
- 1: Full duplex mode (RS485 transmission drivers are switched off if no data sent)
- 2: Full duplex mode (RS422 transmission drivers are not switched off during intermissions)

Range of values: 0..2
Initial value: 2

Command DT

<id>DT<para5> Date- and Time Stamp
Access: Configuration mode (ADMIN)
Description: Completes the output telegrams by date- and/or time information from the internal real time clock (see command RT). This information is mentioned always at the end of the telegram, however, still before check sum.

Parameter description:

- 0: no date- and time stamp
- 1: with date- and time stamp
- 2: with time stamp
- 3: with date stamp

Value range: 0..3
Initial value: 0

FINAL

Command EI

<id>EI<para5> Analogue value in case of error (Error Inversion)
Access: Configuration mode (ADMIN)
Description: Specifies whether 0 or maximum value is output at the analogue outputs in the case of error. If the ULTRASONIC establishes a static error during a measurement, it will output an error under certain conditions. This output is designed to prevent the user from interpreting incorrect measured values. If the analogue signals of the wind direction and wind velocity are used for analysis, the ULTRASONIC connects the outputs in case of error to the maximum resp. minimum output value This parameter is used to specify whether the minimum or maximum value is output in the case of error.

Parameter description:

- 0: Analogue outputs are set to maximum in the case of error
- 1: Analogue outputs are set to 0 in the case of error
- 2: In case of error the analogue output of the wind speed is set to 0
In case of error the analogue output of the wind direction is set to 0
- 3: Analogue output of the wind velocity is set to maximum in case of error.
Analogue output of the wind direction is set to zero in case of error

Value range: 0..3
Initial value: 0

Command ET

<id>ET<para5> Time in ms, until the generic error bit is set (Error Timeout).
Access: Configuration mode (ADMIN)
Description: Determines after which time the generic error bit is set.
The static error bit is set always when the generic error exists more than 60 s.
Special case: with output rates (OR) < 100ms the error time basis reduces by the ratio OR/100.

Value range: 10..60
Initial value: 30

Command HC

<id>HC<para5> Heating Condition
Access: Configuration mode (ADMIN)
Description: The heating switch-off voltage is determined by command HC. With undershooting of this voltage, the heating is no more activated. Example: By „HC10 the heating is deactivated below 10V supply voltage. Only when 12V (10V + 2V hysteresis) is exceeded, the heating can be re-started by the heating control.

Value range: 5..48
Initial value: 10

Command HH

<id>HH<para5> Help
Access: Configuration mode (ADMIN)
Description: With the command HH detailed help can be switched off. (Verbose mode).

Parameter description:

- 0: Detailed message in command mode on (Verbose Mode on). Fastboot off. After a restart the THIES-Bootloader starts first, the main program afterwards.
- 1: messages off, only command echo with ,!' for ex.. !00TT00001 (Verbose Mode off).
- 2: No restart messages are output (Silent Boot Mode).

Value range: 0..2
Initial value: 0

Command HP

<id>HP<para5> Heating Power
Access: Configuration mode (ADMIN)
Description: With this command the maximum heating power can be pre-set. This command is only effective when the heating control is on (see command HT).

Parameter description:

- 0: Full heating power of all system heating, nominally 240W.
- 1: Alternating heating:
cover plate + sensor receiving socket alternating to base plate, nominally 120W.
- 2: Reduced heating power:
cover plate + sensor receiving socket full, base plate reduced from 120W to 80W,
total heating power nominally 200W.
- 3: Reduced heating power:
cover plate and sensor receiving socket full, base plate reduced from 120W to 40W,
total heating power nominally 160W.
- 4: Ultrasonic transducer heating only (for testing only).
- 10: Like parameter „0“, however, heating of US-transducer only in case of disturbed measuring value acquisition.
- 11: Like parameter „1“, however, heating of US-transducer only in case of disturbed measuring value acquisition
- 12: Like parameter „2“, however, heating of US-transducer only in case of disturbed measuring value acquisition
- 13: Like parameter „3“, however, heating of US-transducer only in case of disturbed measuring value acquisition

Value range: 0..4, 10..13
Initial value: 10

Command HT

<<id>HT<para5> Heating control (Heating)
Access: Configuration mode (ADMIN)
Description: To prevent freezing-up the ULTRASONIC is equipped with an effective heating system which keeps the temperature of the ULTRASONIC and its sensors above 0°C. In standard operation the heating is controlled and switched on/off by the housing temperature. Via command HT the function of the heating can be determined.

Parameter description:

- 0: Heating always off
- 1: Heating controlled automatically.
The heating activates automatically with falling temperature at +10 °, and keeps the housing at this temperature.
- 2: Switch-on temperature is adjusted to +40°C; thus, heating turns on already with room temperature (for test purposes only).
- 3: Heating control deactivates when sensor control-line is on level „high“ (see also **Command PU** „Pull-UP“).
- 4: Heating control deactivates when sensor control-line is on level „low“. (see also **Command PU** „Pull-UP“).
- 5: Heating controlled automatically.
Heating power 120W when sensor control-line is level “low”.
Heating power 240W when sensor control-line is level “high”

Value range: 0..5
Initial value: 1

Command ID

<id>ID<para5> ULTRASONIC ID
Access: Configuration mode (ADMIN)
Description: This command is used to specify the ID of the ULTRASONIC. The ID is necessary in every command for addressing of the ULTRASONIC. After changing of the ID the ULTRASONIC responds promptly to the new identification. The ID 99 is a extended ID. The ULTRASONIC always responds to commands with the ID 99 (with the correct baud rate). The ID 99 must not be used, under no circumstances, in bus mode.

Example:

00KY4711	Open with user key
00ID00023	Change ID from 0 to 23
!00ID00023	ULTRASONIC acknowledges change
23DM	Interrogation of duplex mode with new ID
!23DM00000	Response from ULTRASONIC
23ID00000	Change ID from 23 to 0
!23ID00000	ULTRASONIC acknowledges change

Range of values 0..99
Initial value: 0

Command KY

<id>KY<para5> Access mode (Key)
Access: Enquiry mode
Description: To change the parameters of the ULTRASONIC access authorisations are necessary for most commands. This prevents any accidental change in parameters. Access takes place on three levels:

- Query mode "0"
- User mode "1"
- Configuration mode "4711"

Parameter description:

- 0: Query mode
Parameters, which have no access restrictions, are those not stored in the EEPROM, e.g. cyclic telegram enquiry or output of system status.
- 1: User mode (USER ACCESS)
The user key protects parameters, which influence the behaviour of the ULTRASONIC, e.g. averaging period and baud rate. The user can change these parameters but he must realise that a change of the parameter will alter the behaviour of the ULTRASONIC. Before every change it is recommended using the command SS to output and save the current configuration.
- 4711: Configuration mode (ADMIN ACCESS)
Parameters protected with this key, are reserved to the administrator. They are pre-set with the factory-adjustment of instrument.

In case of backspacing from higher to lower access mode by command, the changed parameters are permanently saved. After a restart the system is always switched to the enquiry mode.

Value range 0,1,4711
Initial value 0

Command MD

<id>MD>>para5> Measuring interval (Measurement Delay)
Access: Configuration mode (ADMIN)
Description: Specified the time in 10ms-increments, from the start of a measuring cycle (4 TOF) to the next start. In standard mode this time is 20ms, so that every 20ms a complete data record is made from all sensors.

Value range: 0..30000
Initial value: 2

Command NC

<id>NC<para5> Correction to north (North Correction)
Access: Configuration mode (ADMIN)
Description: With North correction a constant angle is also added to the measured angle. This value is used to correct a known angle error. If the ULTRASONIC is for example not aligned directly to north but to north-east, the wind direction will always show 45° too little. In this case a north correction of 45 must be selected.
North correction affects the output wind directions in the data telegrams as well as the analogue output values.

Range of values 0..359 in 1° increments
Initial value: 0

Command OR

Telegram output interval (Output Rate)
Access: Configuration mode (ADMIN)
Description: With independent telegram output this parameter is used to specify the time interval in which telegrams are output via the serial interface. Specification is made in milliseconds. If the output speed is higher than the transmission speed of the data, the available output is discarded. If the output repeat rate is faster than acquisition of the measured values, the measured values available are double- or multiply output. If the averaging period is 0ms (see Command AV), the averaging period is automatically adapted to the output interval regardless of whether independent telegram output is selected.
See also chapter 8.4.2 , **Command TT**, **Command DM**.

Parameter description: 0: A telegram is output only when the sensor is triggered via the control line. See also **Command TG** and **Command PU** („Pull Up“).
10..10000 Specifies the output interval in milliseconds.

Value range: 0..10000 [ms]
Initial value: 100

Command OS

Scaling of wind velocity output (Output Scale)
Access: Configuration mode (ADMIN)
Description: This command is used to specify in which unit of measurement the wind velocity is output in the serial telegram. Different units of measurement are available for this purpose.

Parameter description:

Parameter	Unit of measurement	Conversion factor related to m/s
0	m/s	1
1	km/h	1m/s => 3.6 km/h
2	miles/h	1m/s => 2.236936292 miles/h
3	knots	1m/s => 1.94253590 kn

Table 7: Conversion factors between different wind velocities

Value range 0..3
Initial value: 0

Command PU

Switchable pull up to control line (approx.5mA, approx. 5V unloaded)
Access: Configuration mode (ADMIN)
Description: The command connects a „pull-up“ power to the control line, so that the ULTRASONIC can be controlled by means of a potential-free switch-contact.
In addition, the control line can be used also as signal output for signalization of instrument conditions by connecting or disconnecting the “pull-up” power.
The „pull-up“ power is not available in the sleep-mode!

Parameter description:

- 0: Pull-up current off (Control line is pulled-down by internal optocoupler).
- 1: Pull-up current on.
- 2: Pull-up current on at exceeding wind warning threshold (operating as output)
- 3: Pull-up current off at exceeding wind warning threshold (operating as output)
- 4: Pull-up current on at general malfunction (operating as output)
- 5: Pull-up current off at general malfunction (operating as output)

Value range: 0..5
Initial value: 0

Command RD

<id>RD<para5> Response delay
Access: Configuration mode (ADMIN)
Description: The command delays the response, after a command via the serial interface, by the mentioned time in ms.

Range of values: 0...1000
Initial value: 5
Unit: ms

Command RS

<id>RS<para5> Restart ULTRASONIC (Reset)
Access: Configuration mode (ADMIN)
Description: With transmission of this command the ULTRASONIC is restarted by the watchdog..

Parameter description:

- 1: The ULTRASONIC performs a warm start. It behaves as after connection of the supply voltage.
- 2: The ULTRASONIC does no longer operate the watchdog. This results in a restart after approx. 11 sec (watchdog test function)

Value range 1..2
Initial value: No initial value

Command RT

<id>RT<para7> For operating the Real Time Clock of the ULTRASONIC (Real Time)
Access: Configuration mode (ADMIN)
Description: Output and Setting of time and date of the ULTRASONIC.

Parameter description:

- T: Output of the system time of the ULTRASONIC in the form: "**hh:mm:ss**".
Example for setting the system time to 12:00 h: "00RTT120000"
- D: Output of system date of the ULTRASONIC in the form: "**dd:mm:yy**".
Example for setting the date to 31.07.2008: "00RTD310708"

Initial value: no initial value

Command SC

<id>SC<para5> For cable break recognition the power- and voltage outputs (Start Current) can be set with their starting value on 20 % of the final value.
Access: Configuration mode (ADMIN)

Parameter description:

- 0: Characteristic line of analogue outputs: 0..20mA / 0..10V
- 1: Characteristic line of analogue outputs: 4..20mA / 2..10V

Initial value: depending on instrument

Command SN

<id>SN Output of the 8-digit serial number (Serial Number)
Access: Query mode
Description: On factory-adjustment, each ULTRASONIC is equipped with a serial number. The ULTRASONIC can clearly be identified by this serial number.

Parameter description:

The ULTRASONIC responds, for ex., to serial-number „12345678“:

!00SN12345678

Serial number: 12345678 (see also command HH “Verbose ON”)

Value range: 0..99999999

Command SM

<id>SM<para5> Energy saving mode (Sleep Mode)
Access: Configuration mode (ADMIN)
Description: For energy-saving operation there is an energy saving mode available in 2 alternatives. In the energy saving mode the processor cycle is switched off during the measurement pause. Thus, the power consumption drops to approx. 4mA during these pauses. Prerequisite for an energy saving mode is:
1. the output rate is reset (to 0), see command OR
2. the measurement delay is reset (to 0), see command MD
3. the heating control is switched off, see also command HT
Reasonable is also to switch off the averaging AV=0 (see command AV).

Parameter description:

0: ULTRASONIC is always switched on (standard)

1..600: energy saving mode, telegram output every 1..600s by internal clock pulse

1000: energy saving mode, telegram output by operating the sensor control line, see also command TG and Command PU.

Value range: 0..600, 1000

Command SS

<id>SS<para5> System status (System Status)
Access: Query mode
Description: Outputs the selected parameters of all commands. All parameters stored in the EEPROM are output here. Before parameters of the ULTRASONIC are changed, this command should be used to generate and save a list of the selected parameters, e.g. by copying parameters to a text file.

Parameter description:

No parameter is necessary when using the command SS. Call-up with selected instrument - ID 00 is as follows:

00SS<cr> with <cr> Carriage return (Enter key)

Command SU

<id>SU<para5> Preparing a Firmware Upload (Software Upload)
Access: Configuration mode (ADMIN)
Description: Starts the „On Chip“ Bootloader for preparing a firmware-update.

The required upload-baud rate (see BR) should be set before firmware-update. With a maximum baud rate of 115200 baud the firmware-upload lasts approx. 2min. From initiating of this procedure until the „firmware-upload“ should not pass more than 30s, because after a total of 3 min the ULTRASONIC restarts automatically, regardless of whether the “upload” was done or not. An early break may result in the ULTRASONIC not responding any more to commands. It must be sent in to the manufacturer.

Command SV

<id>SV<para5> Software version
Access: Query mode
Description: The command outputs the start message with the current software version.

Command TA

<id>TA Thies order number
Access: Query mode
Description: The command outputs the factory-determined Thies order number for example: 4.3875.00.340

Command TG

<id>TG<para5> Trigger characteristic of the control line (TriGger)
Access: Configuration mode (ADMIN)
Description: Definition of the necessary voltage status for controlling the telegram output via the sensor control line, see also Command PU.
When using the trigger for the telegram output, first the requested telegram should be selected by means of “TT”, and afterwards the output rate (parameter “OR”) must be reset, so that the telegram is output only in case of a trigger event.

Parameter description:

- 0: Controlling switched off via the control line.
- 1: Telegram output with rising edge of control voltage
- 2: Telegram output with falling edge of control voltage
- 3: Telegram output while the control voltage is „high“.
- 4: Telegram output while the control voltage is „low“

Value range: 0..4
Initial value: 0

Command TI

<id>TI<para5>	Telegram Information
Access:	Query mode
Description:	Output of a telegram information about the type of the measuring value in short form.
Parameter description:	
	0: Output of a brief information to the telegram, see command TT 1,2,3,4,7,8,9,12 Output of a brief information to telegram 1,2,3,4,7,8,9,12
Value range:	0,1,2,3,4,7, 8,9,12 Valid telegrams see also Command TR .
Initial value:	0

Command TR

<id>TR<para5>	Telegram Request (Telegram request)
Access:	Query mode
Description:	The command TR is used to specifically request a telegram from the ULTRASONIC. After interpretation the ULTRASONIC sends back the requested telegram. The instrument specifies a series of predefined telegrams, as well as option for the user to configure his own telegram: see Fixed telegram formats, User-specific telegram. In half duplex mode the command TR is the sole option for requesting measured values via the RS485 interface. The response time of the ULTRASONIC with a telegram request is defined as follows: The time interval after receipt of the last character until transmission of the first character of the response telegram is < 50ms (measured at RXD+ and TXD+ of RS485). The command RD can be used for delaying the response of the ULTRASONIC.
Parameter description:	
	1: VD telegram (wind velocity, wind direction) 2: VDT telegram (wind velocity, wind direction, virtual temperature) 3: VD2 telegram (wind velocity and wind direction with higher resolution) 4: NMEA V2.0 7: Velocity components Vx and Vy 8: VDM telegram (wind velocity, wind direction and voltage supply monitor) 9: VDPM telegram (wind speed, wind direction, air pressure and supply-voltage-monitor) 11: PBT telegram (16 bit binary value of wind velocity, wind direction, virtual temperature and air pressure) 12: Scientific diagnostic telegram
Value range	1,2,3,4,7,8,9,11,12
Initial value:	No initial value

Command TT

<id>TT<para5>	Autonomous telegram output (Telegram Transmission)
Access:	User mode
Description:	Determines the number of the telegram, which the ULTRASONIC sends cyclic-autonomously. The telegrams available are the same as specified under Command TR . Command OR determines the time interval for transmitting the telegrams. In the half duplex mode (see command DM) the independent telegram output starts only 10s after the last command, or 20 s after the re-start. Thus, the ULTRASONIC can be re-programmed or resp., the new configuration can be saved.
Value range	1,2,3,4,7,8,9,12
Initial value:	0

Command WD

<id>WD<UUULLL> Wind warning Delay
Access: Configuration mode (ADMIN)
Description: In order to prevent turbulent output conditions at the warning thresholds it is possible to set an on- and off-delay.
WD specifies the delay from detection to reaction of the upper and lower threshold, see **Command PU** and **Command WW**.
UUULLL -> 'UUU' upper and 'LLL' lower threshold delay in steps of seconds

Value range 000000..600600
Initial value: 0

Command WW

<id>WD<UUULLL> Wind Warning
Access: Configuration mode (ADMIN)
Description: It specifies the Pull Up on/off criterion of the control pin, see PU.
UUULLL -> 'UUU' upper and 'LLL' lower threshold of velocity criterion in steps of 0.1m/s
Rising wind speed exceeding upper threshold enables the criterion and descending wind speed below lower threshold disables the criterion.
Herewith a free hysteresis is programmable.

Value range 000000..750750
Initial value: 0

FINAL

12 Appendix 1 Predefined data telegrams

12.1 Telegram 1 VD

Wind speed and wind direction

Command: TR1 Command: TT1

Construction of telegram:

VD (STX)xx.x xxx*xx(CR)(ETX)

CH. NO.	Function
1	STX (HEX 02)
2	10 ¹ wind velocity
3	10 ⁰ wind velocity
4	. decimal point (HEX 2E)
5	10 ⁻¹ wind velocity
6	Blank character (HEX 20)
7	10 ² wind direction
8	10 ¹ wind direction
9	10 ⁰ wind direction
10	* (HEX 2A) checksum identifier
11	High byte checksum in HEX (2..9)
12	Low byte checksum in HEX (2..9)
13	CR (HEX 0D) Carriage return
14	ETX (HEX 03)

Telegram output in case of error

CH. NO.	Function
1	STX (HEX 02)
2	'F'
3	'F'
4	. decimal point (HEX 2E)
5	'F'
6	Blank character (HEX 20)
7	'F'
8	'F'
9	'F'
10	* (HEX 2A) checksum identifier
11	High byte checksum in HEX (2..9)
12	Low byte checksum in HEX (2..9)
13	CR (HEX 0D) Carriage return
14	ETX (HEX 03)

12.2 Telegram 2 VDT

Wind speed, wind direction, acoustic-virtual temperature

Command: TR2 command: TT2

Construction of telegram:

(STX)xx.x xxx xxx.x xx*xx(CR)(ETX)

CH. NO.	FUNCTION
1	STX (HEX 02)
2	10 ¹ wind velocity
3	10 ⁰ wind velocity
4	. decimal point (HEX 2E)
5	10 ⁻¹ wind velocity
6	Blank character (HEX 20)
7	10 ² wind direction
8	10 ¹ wind direction
9	10 ⁰ wind direction
10	Blank character (HEX 20)
11	+ or - sign
12	10 ¹ temperature
13	10 ⁰ temperature
14	. decimal point (HEX 2E)
15	10 ⁻¹ temperature
16	Blank character (HEX 20)
17	High byte status byte
18	Low byte status byte
19	* (HEX 2A) checksum identifier
20	High byte checksum in HEX (2..18)
21	Low byte checksum in HEX (2..18)
22	CR (HEX 0D) Carriage return
23	ETX (HEX 03)

Telegram output in case of error

CH. NO.	FUNCTION
1	STX (HEX 02)
2	'F'
3	'F'
4	. decimal point (HEX 2E)
5	'F'
6	Blank character (HEX 20)
7	'F'
8	'F'
9	'F'
10	Blank character (HEX 20)
11	'F'
12	'F'
13	'F'
14	. decimal point (HEX 2E)
15	'F'
16	Blank character (HEX 20)
17	High byte status byte
18	Low byte status byte
19	* (HEX 2A) checksum identifier
20	High byte checksum in HEX (2..18)
21	Low byte checksum in HEX (2..18)
22	CR (HEX 0D) Carriage return
23	ETX (HEX 03)

12.3 Telegram 3 VD2

Wind speed, wind direction with higher resolution

Command TR3 Command: TT3

Construction of telegram:
(STX)xxx.xx xxx.x*xx(CR)(ETX)

CH. NO.	FUNCTION
1	STX (HEX 02)
2	10 ² wind velocity
3	10 ¹ wind velocity
4	10 ⁰ wind velocity
5	. decimal point (HEX 2E)
6	10 ⁻¹ wind velocity
7	10 ⁻² wind velocity
8	Blank character (HEX 20)
9	10 ² wind direction
10	10 ¹ wind direction
11	10 ⁰ wind direction
12	. decimal point (HEX 2E)
13	10 ⁻¹ wind direction
14	* (HEX 2A) checksum identifier
15	High byte checksum in HEX (2..13)
16	Low byte checksum in HEX (2..13)
17	CR (HEX 0D) Carriage return
18	ETX (HEX 03)

Telegram output in case of error

CH. NO.	FUNCTION
1	STX (HEX 02)
2	'F'
3	'F'
4	'F'
5	. decimal point (HEX 2E)
6	'F'
7	'F'
8	Blank character (HEX 20)
9	'F'
10	'F'
11	'F'
12	. decimal point (HEX 2E)
13	'F'
14	* (HEX 2A) checksum identifier
15	High byte checksum in HEX (2..13)
16	Low byte checksum in HEX (2..13)
17	CR (HEX 0D) Carriage return
18	ETX (HEX 03)

12.4 Telegram 00004

NMEA

NMEA V 2.0

Command: TR4 Command TT4

Construction of telegram: \$WIMWV,xxx.x,R,xxx.x,N,A*xx(CR)(LF)

CH. NO.	FUNCTION
1	\$ (HEX 24) dollar
2	W (HEX 57)
3	I (HEX 49)
4	M (HEX 4D)
5	W (HEX 57)
6	V (HEX 56)
7	, (HEX 2C) comma
8	10 ² wind direction
9	10 ¹ wind direction
10	10 ⁰ wind direction
11	. (HEX 2E) decimal point
12	10 ⁻¹ wind direction
13	, (HEX 2C) comma
14	R (HEX 52)
15	, (HEX 2C) comma
16	10 ² wind velocity
17	10 ¹ wind velocity
18	10 ⁰ wind velocity
19	. (HEX 2E) decimal point
20	10 ⁻¹ wind velocity
21	, (HEX 2C) comma
22	K, N, M, S = km/h, Knots, m/s, mph
23	, (HEX 2C) comma
24	A, V A = valid, V = invalid
25	* (HEX 2A) checksum identifier
26	High byte checksum in HEX (2..24)
27	Low byte checksum in HEX (2..24)
28	CR (HEX 0D) Carriage return
29	LF (HEX 0A) Line feed

Telegram output in case of error

CH. NO.	FUNCTION
1	\$ (HEX 24) dollar
2	W (HEX 57)
3	I (HEX 49)
4	M (HEX 4D)
5	W (HEX 57)
6	V (HEX 56)
7	, (HEX 2C) comma
8	, (HEX 2C) comma
9	R (HEX 52)
10	, (HEX 2C) comma
11	, (HEX 2C) comma
12	K, N, M, S = km/h, Knots, m/s, mph
13	, (HEX 2C) comma
14	V (V = invalid)
15	* (HEX 2A) checksum identifier
16	High byte checksum in HEX (2..14)
17	Low byte checksum in HEX (2..14)
18	CR (HEX 0D) Carriage return
19	LF (HEX 0A) Line feed

12.5 Telegram 7 Vx, Vy, VT

Wind velocity components Vx und Vy

Command: TR7 Command: TT7

Construction of telegram:

(STX)xxx.x;xxx.x;xxx.x;xx;xx(CR)(ETX)

CH. NO.	FUNCTION
1	STX (HEX 02)
2	+ or - sign
3	10 ¹ wind velocity X
4	10 ⁰ wind velocity X
5	. (HEX 2E) decimal point
6	10 ⁻¹ wind velocity X
7	; (semicolon)
8	+ or - sign
9	10 ¹ wind velocity Y
10	10 ⁰ wind velocity Y
11	. (HEX 2E) decimal point
12	10 ⁻¹ wind velocity Y
13	; (semicolon)
14	+ or - sign
15	10 ¹ temperature
16	10 ⁰ temperature
17	. (HEX 2E) decimal point
18	10 ⁻¹ temperature
19	; (semicolon)
20	High Byte status byte
21	Low Byte status byte
22	; (semicolon)
23	High Byte check sum in HEX (1..22)
24	Low Byte check sum in HEX (1..22)
25	CR (HEX 0D) Carriage Return
26	ETX (HEX 03)

Telegram output in case of error

CH.NO.	FUNCTION
1	STX (HEX 02)
2	+
3	F
4	F
5	. (HEX 2E) decimal point
6	F
7	; (Semicolon)
8	+
9	F
10	F
11	. (HEX 2E) decimal point
12	F
13	; (Semicolon)
14	+
15	F
16	F
17	. (HEX 2E) decimal point

18	F
19	; (Semicolon)
20	High Byte status byte
21	Low Byte status byte
22	; (Semicolon)
23	High Byte Check sum in HEX (1..22)
24	Low Byte Check sum in HEX (1..22)
25	CR (HEX 0D) Carriage Return
26	ETX (HEX 03)

12.6 Telegram 8 VDM

Wind speed, wind direction with higher resolution and supply voltage monitor

Command: TR8 Command: TT8

Construction of telegram:

(STX)xx xxx.xx xxx.x xx xx*xx(CR)(ETX)

CH. NO.	FUNCTION
1	STX (HEX 02)
2	10 ¹ Sensor ID
3	10 ⁰ Sensor ID
4	Blank Character (HEX 20)
5	10 ² Wind Velocity
6	10 ¹ Wind Velocity
7	10 ⁰ Wind Velocity
8	. Decimal Point (HEX 2E)
9	10 ⁻¹ Wind Velocity
10	10 ⁻² Wind Velocity
11	Blank Character (HEX 20)
12	10 ² Wind Direction
13	10 ¹ Wind Direction
14	10 ⁰ Wind Direction
15	. Decimal Point (HEX 2E)
16	10 ⁻¹ Wind Direction
17	Blank Character (HEX 20)
18	Status Byte (High Byte)
19	Status Byte (Low Byte)
20	Blank Character (HEX 20)
21	Supply Voltage Monitor (HEX High Byte)
22	Supply Voltage Monitor (HEX Low Byte)
23	* (HEX 2A) Checksum Identifier
24	High byte checksum in HEX (2..22)
25	Low byte checksum in HEX (2..22)
26	CR (HEX 0D) Carriage return
27	ETX (HEX 03)

Telegram output in case of error

CH. NO.	FUNCTION
1	STX (HEX 02)
2	10 ¹ Sensor ID
3	10 ⁰ Sensor ID
4	Blank Character (HEX 20)
5	'F'
6	'F'
7	'F'

8	. Decimal Point (HEX 2E)
9	'F'
10	'F'
11	Blank Character (HEX 20)
12	'F'
13	'F'
14	'F'
15	. Decimal Point (HEX 2E)
16	'F'
17	Blank Character (HEX 20)
18	Status Byte (High Byte)
19	Status Byte (Low Byte)
20	Blank Character (HEX 20)
21	Supply Voltage Monitor (HEX High Byte)
22	Supply Voltage Monitor (HEX Low Byte)
23	* (HEX 2A) checksum identifier
24	High byte checksum in HEX (2..22)
25	Low byte checksum in HEX (2..22)
26	CR (HEX 0D) Carriage return
27	ETX (HEX 03)

12.7 Telegram 9 VDPM

Wind speed, wind direction with higher resolution, air pressure (optional) and Supply-voltage-monitor

command: TR9 command: TT9

Telegram construction:

(STX)xx xxx.xx xxx.x xxxx.x xx xx*xx(CR)(ETX)

CH. NO.	Function
1	STX (HEX 02)
2	10 ¹ Sensor ID
3	10 ⁰ Sensor ID
4	Blank character (HEX 20)
5	10 ² Wind Velocity
6	10 ¹ Wind Velocity
7	10 ⁰ Wind Velocity
8	. decimal point (HEX 2E)
9	10 ⁻¹ Wind Velocity
10	10 ⁻² Wind Velocity
11	Blank character (HEX 20)
12	10 ² Wind Direction
13	10 ¹ Wind Direction
14	10 ⁰ Wind Direction
15	. Decimal point (HEX 2E)
16	10 ⁻¹ Wind direction
17	Blank character (HEX 20)
18	'F' (optional: 10 ³ air pressure)
19	'F' (optional: 10 ² air pressure)
20	'F' (optional: 10 ¹ air pressure)
21	'F' (optional: 10 ⁰ air pressure)
22	. Decimal point (HEX 2E)
23	'F' (optional: 10 ⁻¹ air pressure)
24	Blank character (HEX 20)
25	Status Byte (High Byte)
26	Status Byte (Low Byte)
27	Blank character (HEX 20)

28	Supply-voltage-monitor (HEX High Byte)
29	Supply-voltage-monitor (HEX Low Byte)
30	* (HEX 2A) Checksum identifier
31	High byte Checksum in HEX (2..29)
32	Low byte Checksum in HEX (2..29)
33	CR (HEX 0D) Carriage return
34	ETX (HEX 03)

Telegram output in case of error

CH. NO.	Function
1	STX (HEX 02)
2	10 ¹ Sensor ID
3	10 ⁰ Sensor ID
4	Blank character(HEX 20)
5	'F'
6	'F'
7	'F'
8	. Decimal point (HEX 2E)
9	'F'
10	'F'
11	Blank character (HEX 20)
12	'F'
13	'F'
14	'F'
15	. Decimal point (HEX 2E)
16	'F'
17	Blank character (HEX 20)
18	'F'
19	'F'
20	'F'
21	'F'
22	. Decimal point (HEX 2E)
23	'F'
24	Blank character (HEX 20)
25	Status Byte (High Byte)
26	Status Byte (Low Byte)
27	Blank character (HEX 20)
28	Supply-voltage-monitor (HEX High Byte)
29	Supply-voltage-monitor (HEX Low Byte)
30	* (HEX 2A) Checksum identifier
31	High byte checksum in HEX (2..29)
32	Low byte checksum in HEX (2..29)
33	CR (HEX 0D) Carriage return
34	ETX (HEX 03)

12.8 Telegram 11 PBT

Wind velocity, wind direction and acoustic-virtual temperature

Command: TR11 Command: TT11

Telegram construction:

(STX)xx.x xxx xxx.x xx*xx(CR)(ETX)

Character No.	Normal function	Output in error case
1-3	PBT (3 Bytes HEX 50 42 54)	PBT as normal function
4-5	Wind velocity in 1/10 m/s (2 byte binary)	0xFFFF (binary Low-Byte High-Byte)
6-7	Wind direction in ° (2 Byte binary)	0xFFFF (binary Low-Byte High-Byte)
8-9	Temperature 1/10°C (2 signed byte binary)	0xFF7F (binary Low-Byte High-Byte)
10-11	Air pressure in 1/10 hPa (2 Byte binary) *	0xFFFF (binary Low-Byte High-Byte) *
12-13	Status word (2 byte binary)	Status word as normal function
14	Check sum XOR from 1. to 13. byte (1 byte)	Check sum as normal function

* The air pressure is optional; here is - if not available - always „0xffff“ (2 byte binary) output.

12.9 Telegram 12 Scientific Telegram

Scientific Diagnostic Telegram

Command: TR12 Command: TT12

Construction of telegram:

WG;WR;VT;V13;V24;T13;T24;C31;C42;C13;C24;N1;N2;N3;N4;TS;TC

WG	Wind speed (7,2;)
WR	Wind direction (6,2;)
VT	Virtual temperature (6,2;)
V13	Speed of distance 13 (7,2;)
V24	Speed of distance 24 (7,2;)
T13	Virtual temperature of distance 13 (7,2;) (last measured value in averaging interval; - 273,15 in case of no valid value)
T24	Virtual temperature of distance 24 (7,2;) (last measured value in averaging interval; - 273,15 in case of no valid value)
SN	Measuring value run-time Converter 1 in direction Converter 3 (north- south direction) (5;)
WE	Measuring value run-time Converter 2 in direction Converter 4 (east- west direction) (5;)
NS	Measuring value run-time Converter 3 in direction Converter 1 (south- north direction) (5;)
EW	Measuring value run-time Converter 4 in direction Converter 2 (west- east direction) (5;)
PA	Internal counter (5;), pre-averaging (100ms) (5;)
INTER	Time interval, where the values are written into the main average memory (5;)
AV	Number of values in the main average memory (5;)
Sth	THIES Status (2;)(hexadecimal display)
STgen	Telegram status , see 8.4.5.1 (hexadecimal display) (4;)
LC	Internal tick count in ms of the processor (7;\r\n)

Signification (7,2;) (x;y)

X = Number of digits in the telegram

Y = Number of decimal places

For example (7;2;) = 0000.00;

13 Technical Data

Wind velocity	Measuring range	0,01 m/s...75 m/s Scaling of analogue output freely selectable	
	Accuracy	≤ 5 m/s:	± 0,2 m/s (rms, mean over 360°)
		5...60m/s:	± 2% of meas. value (rms- mean over 360°)
		60...75m/s:	± 3% of meas. value (rms- mean over 360°)
	Resolution	0,1 m/s:	In the telegrams: 1, 2, 4, 7
		0,01 m/s:	in the telegram 3
	Starting velocity / Threshold	0.01 m/s	
Wind direction	Measuring range	0°...360°	
	Accuracy	± 2.0° at WV > 1 m/s	
	Resolution	1°:	In the telegrams 1, 2
		0,1°:	in telegrams 3, 4
Virtual temperature	Measuring range	- 50°C... + 70 °C	
	Accuracy	± 2,0 K	
	Resolution	0.1 K (in the telegrams 2 and 7)	
Air pressure	Measuring range	300 hPa...1100hPa	
	Accuracy	± 0,25 hPa at 700...1050 hPa and +25...+40°C ± 2,0 hPa at 300...1100 hPa, -40...+60°C and activated heating	
	Resolution	0,1 hPa	
	Long-term stability	< ± 1 hPa per year	
Data output digital	Interface	RS 485 / RS 422 Galvanically isolated from supply and housing	
	Baud rate	1200, 2400, 4800, 9600, 19200, 38400, 57600, 115200, 230400, 460800, 921600 adjustable	
	Output	Instantaneous values,. gliding mean values freely selectable from 100 msec to 2 min in increments of 100 msec	
	Output rate	1 per 10msec to 1 per 10 seconds freely selectable in increments of 1 msec	
	Status identification	Heating, failure of measurement path , ΔT path temperatures	
Data output analogue	Electrical outputs	0 ...20 mA / 0... 10 V or 4... 20 mA / 2... 10 V Galvanically isolated from supply and housing	
		Burden on current output maximum 300Ω	
		Burden on voltage output minimum 2000Ω	
	Output	Instantaneous values Gliding mean values from 100 msec to 2 min freely selectable in increments of 100 msec.	
	Output rate	Updating rate 10 msec	
	Resolution	16 bit	
General	Internal measuring rate	Up to 1000 runtime-measurements per seconds, up to 250 complete measurement sequences/second inclusive calculations	
	Bus mode	Bus mode with up to 99 instruments possible	

	Firmware update	Firmware update in full-duplex mode via RS422
	Temperature range	Operating temperature – 50°C... + 80°C heated – 30°C... + 80°C unheated Storing – 50°C... + 80°C Measuring operation possible with heating up to - 75°C
Operating voltage	Supply w/o heating	U: 8V...60 V DC oder 5 12V...42V AC 45Hz...65Hz P: typ. 1,0 VA, max. 1,2 VA
Operating voltage	Supply with heating	U: 24 V AC/DC ±15%, 45...65Hz P: typ. 240VA, max. 250 VA @ 24V
	Protection	IP 68 - applies with proper installation, see section "Preparation for operation") - does not apply with instrument with optional baro transmitter
W/o US converter heating	Icing resistance	Acc. to THIES STD 012001
With US converter heating	Icing resistance	Acc. to THIES STD 012002
	EMC	EN 61326, 61000-6-2, 61000-6-3
Housing		Aluminium, seawater-resistant Surface: hard-anodized with basic colouring Coat thickness: 40-60 µm
	Installation type	e. g. Mast tube R 1½ " (Ø 48,3 mm)
	Connection type	8-pole plug connection in shaft
	Weight	approx. 2 kg

FINAL

14 Dimension Drawing

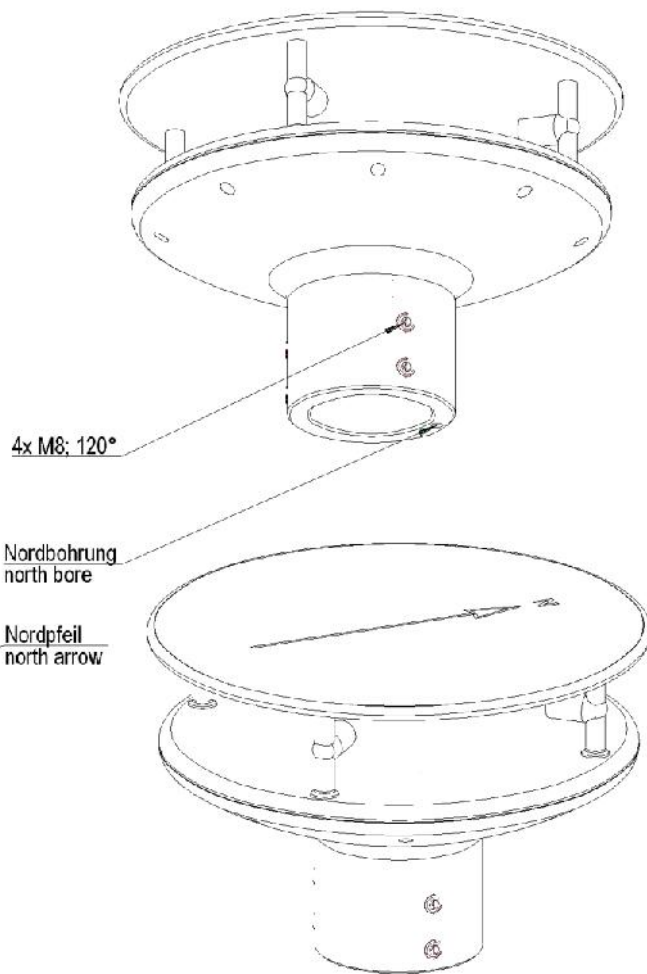
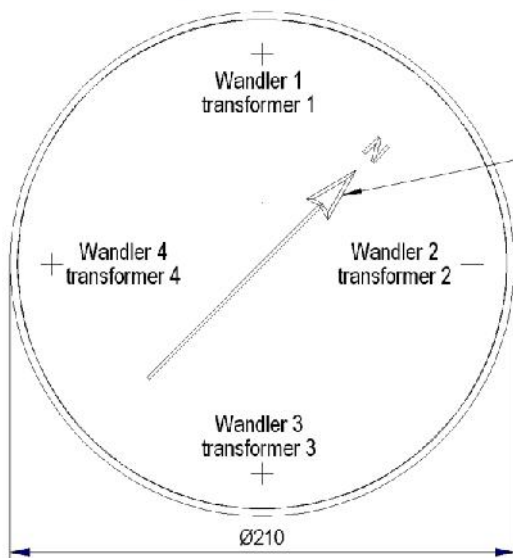
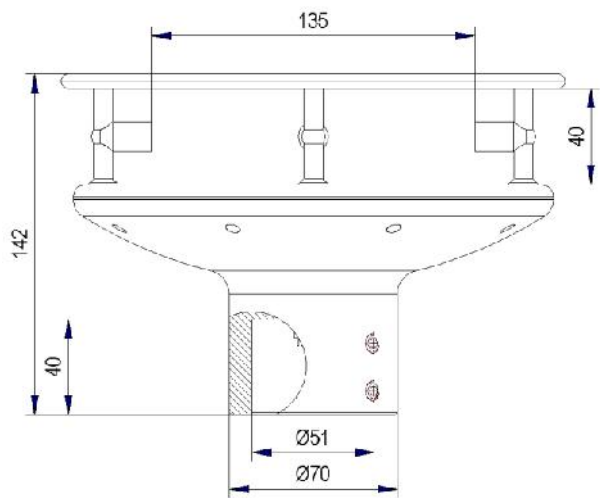

FINAL

15 Accessories (available as optional features)

Connecting cable, complete	507751	15 m cable (Type: PUR/C/PP 4x0,75+2x2x0,14) with socket outlet on transmitter side. The other end of the cable is equipped with core identification rings
PC-Program Meteo-Online	9.1700.98.000	For graphical display of measured values on a PC
Interface converter	9.1702.xx.000	For RS 422 signal conversion in RS 232
Lightning rod	4.3100.99.150	As lightning protection
Power supply unit compact	9.3389.10.100	For the power supply of the Ultrasonic Anemometer 2D compact Primary: 230 V 50Hz, 250 W

Attention:

Due to the expected power loss of the connecting cable, the power supply unit for the anemometer shall be dimensioned respectively.

FINAL

16 EC-Declaration of Conformity

Document-No.: 000607

Month: 05 Year: 16

Manufacturer: **ADOLF THIES GmbH & Co. KG**

Hauptstr. 76
D-37083 Göttingen
Tel.: (0551) 79001-0
Fax: (0551) 79001-65
email: Info@ThiesClima.com

This declaration of conformity is issued under the sole responsibility of the manufacturer

Description of Product: **Ultrasonic Anemometer 2D compact**

Article No.	4.3870.00.490	4.3871.00.000	4.3871.00.260	4.3871.00.300
4.3871.00.340	4.3871.00.540	4.3871.00.740	4.3871.01.300	4.3871.01.310
4.3871.01.317	4.3871.01.318	4.3871.01.319	4.3871.02.300	4.3871.02.310
4.3875.00.000	4.3875.00.030	4.3875.00.260	4.3875.00.300	4.3875.00.309
4.3875.00.340	4.3875.00.346	4.3875.00.460	4.3875.00.540	4.3875.00.541
4.3875.01.300	4.3875.01.310	4.3875.01.311	4.3875.01.316	4.3875.01.317
4.3875.01.319	4.3875.01.400	4.3875.02.300	4.3875.02.310	4.3875.04.319
4.3875.04.349	4.3875.05.310	4.3875.10.000	4.3875.14.319	4.3875.14.349
4.3875.21.310	4.3875.40.000	4.3875.40.340		

specified technical data in the document: **021545/03/14; 021636/10/10**

The indicated products correspond to the essential requirement of the following European Directives and Regulations:

2014/30/EU	DIRECTIVE 2014/30/EU OF THE EUROPEAN PARLIAMENT AND OF THE COUNCIL of 26 February 2014 on the harmonisation of the laws of the Member States relating to electromagnetic compatibility
2014/35/EU	DIRECTIVE 2014/35/EU OF THE EUROPEAN PARLIAMENT AND OF THE COUNCIL of 26 February 2014 on the harmonisation of the laws of the Member States relating to the making available on the market of electrical equipment designed for use within certain voltage limits
552/2004/EC	Regulation (EC) No 552/2004 of the European Parliament and the Council of 10 March 2004 on the interoperability of the European Air Traffic Management network (the interoperability Regulation)
2011/65/EU	DIRECTIVE 2011/65/EU OF THE EUROPEAN PARLIAMENT AND OF THE COUNCIL of 8 June 2011 on the restriction of the use of certain hazardous substances in electrical and electronic equipment
2012/19/EU	DIRECTIVE 2012/19/EU OF THE EUROPEAN PARLIAMENT AND OF THE COUNCIL of 4 July 2012 on waste electrical and electronic equipment (WEEE)

The indicated products comply with the regulations of the directives. This is proved by the compliance with the following standards:

EN 61000-6-2	Electromagnetic compatibility Immunity for industrial environment
EN61000-4-4 level 4 4kV	Electromagnetic compatibility (EMC) – Part 4-4: Testing and measurement techniques – Electrical fast transient/burst immunity test
EN61000-4-5 level 4 4kV	Electromagnetic compatibility (EMC) – Part 4-5: Testing and measurement techniques – Surge immunity test
EN 61000-6-3	Electromagnetic compatibility Emission standard for residential, commercial and light industrial environments
EN 61010-1	Safety requirements for electrical equipment for measurement, control, and laboratory use. Part 1: General requirements
EN 50581	Technical documentation for the assessment of electrical and electronic products with respect to the restriction of hazardous substances
IEC 60945	Maritime navigation and radiocommunication equipment and systems Part 8.7 Vibration Part 8.12 Test Kb: Salt mist, cyclic (sodium, chloride solution) Part 9 Test of emission Part 10 Test of immunity Part 11.2 Safe distance to magnetic-compass Part 12.1 Degrees of protection provided by enclosures

Place: Göttingen

Date: 02.05.2016

Signed for and on behalf of:

Legally binding signature:

issuer:

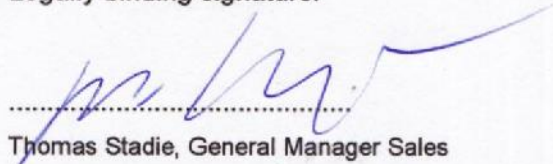

Thomas Stadie, General Manager Sales

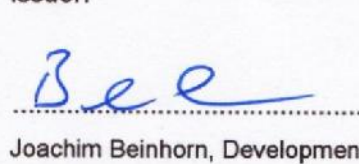

Joachim Beinhorn, Development Manager

This declaration certifies the compliance with the mentioned directives, however does not include any warranty of characteristics. Please pay attention to the security advises of the provided instructions for use.

FINAL

FINAL



Official BeNeLux distributor: www.catec.nl
Catec
MEETINSTRUMENTATIE



- Alterations reserved -